

JANUARY, 1924

# Radio Topics



20 Cents

Monel Holmquist - Oak Park



# **M** ANHATTAN ELECTRICAL SUPPLY CO., INC.

MAKERS OF THE FAMOUS



**M** ANHATTAN

"The Loud Speaker with Concert Modulator"

**M** ANHATTAN  
LOUD SPEAKER

Oldest and Largest Distributors of

Radio  Corporation  
of America

GREBE RADIO

*The Manhattan Loud Speaker  
with its "concert modulator"  
gives real tone quality.*

KENNEDY  
EQUIPMENT

114 SO. WELLS ST., CHICAGO

NEW YORK

ST. LOUIS

SAN FRANCISCO

"THE AIR IS FULL OF THINGS YOU SHOULDN'T MISS"



Radio has moved from the laboratory and amateur's work-table out into the refined surroundings of the family living room. In keeping with this new companionship we offer this reliable, long-lived Eveready "B" Battery, in an attractive, new metal case, worthy to stand beside the rich cabinets of fine radio sets.

Eveready "B", 22½ volts, No. 766 with Six Fahnestock Spring Clip Connectors.



## When Radio called, Eveready was ready

TWENTY-ONE years ago, when wireless telegraphy had its first birthday, National Carbon Company's dry cell batteries were nine years old. Even then its batteries were world famous as convenient, economical and efficient sources of electric energy.

With the introduction of broadcasting, radio leaped into universal service. Radio engineers used Eveready Batteries as their standard in designing tubes and receiving sets. Eveready engineers, backed by the most complete research and testing laboratories known to the industry, worked with

them to discover how the known dry cell could be improved for radio work.

The fruit of these efforts is the Eveready family of radio batteries, conspicuous for vitality and endurance—the right battery by test and proof for every radio use.

To be certain of battery satisfaction, insist on Eveready Radio Batteries—they last longer. All reliable radio dealers sell them.

Informative and money-saving booklets on Radio Batteries sent free on request.

NATIONAL CARBON COMPANY, INC., New York, N. Y.

### Headquarters for Radio Battery Information

If you have any battery problem, write to RADIO DIVISION, NATIONAL CARBON COMPANY, INC.  
106 Orton Street, Long Island City, N. Y.

Eveready 6-volt Storage Battery



Eveready Radio "A" Dry Cell  
Specially manufactured for use with low amperage tubes



No. 764 The Space Saver Vertical 22½-volt "B" Battery

No. 767 "B" Battery, 45 volts Variable taps Fahnestock Clips

Eveready Three or "C" Battery Clarifies tone and increases "B" Battery life



# EVEREADY Radio Batteries

*—they last longer*

CLASS OF SERVICE		SYMBOL
Telegram		
Day Letter		Blue
Night Message		Nite
Night Letter		N L

If none of these three symbols appears after the check (number of words) this is a telegram. Otherwise its character is indicated by the symbol appearing after the check.

Form 1204

CLASS OF SERVICE		SYMBOL
Telegram		
Day Letter		Blue
Night Message		Nite
Night Letter		N L

If none of these three symbols appears after the check (number of words) this is a telegram. Otherwise its character is indicated by the symbol appearing after the check.

**WESTERN UNION**  
**TELEGRAM**

NEWCOMB CARLTON, PRESIDENT      GEORGE W. E. ATKINS, FIRST VICE-PRESIDENT

RECEIVED AT 21 NORTH WASHINGTON ST.  
JAMAICA, N.Y.

49N CO 41 COLLECT BLUE

AVALON CALIF 925A NOV 27 1923

DOUGLAS RIGNEY

A. H. GREBE AND CO. VANWYCK BLVD RICHMOND HILL NY

USING GREBE THIRTEEN BROKE ALL SPEED RECORDS EARLY TODAY STOP  
RECEIVED MESSAGE FOR MIX FROM BOYD PHELPS STATION ONE HAVE XRAY  
HARTFORD CONNECTICUT DIRECT STOP TRANSMITTED DIRECT TO MIX AND  
RETURNED ANSWER TO HARTFORD IN FIVE MINUTES AND SIX SECONDS

MAJOR LAWRENCE MOTT

220P



*"It is only when the cold season comes that we know the pine and cypress to be ever-greens."*

—Confucius.

*In the real test of DX performance the Grebe "13" establishes its true merit.*

*Doctor Wu*

## California to the Arctic

Again it is our privilege to congratulate Major Lawrence Mott, 6 XAD-6ZW upon a splendid achievement.

Effecting direct communication with both Hartford and the "Bowdoin" and relaying a message and its answer between them is a feat of which anyone might well be proud.

That so able an operator as Major Mott should use a Grebe "13" for such work is significant.

Ask your dealer or write us.

**A. H. GREBE & CO., Inc.**

77 Van Wyck Blvd., Richmond Hill, N. Y.

Western Branch: 451 East 3rd Street, Los Angeles, Cal.



Licensed under Armstrong  
U. S. Patent No. 1,113,149

# Radio Topics

An Illustrated Monthly Devoted to Radio

Volume III

January, 1924

Number 12



## "THAT BIRD CAN CERTAINLY SING"

The gentleman on the left remarks. This is Hoot Gibson, Universal Pictures Star, his director, Edward Sedgwick; his leading lady, Laura LaPlante, and members of the "Hook and Ladder" company, listening to a concert over a Grebe receiver CR-12.

## CONTENTS

Cover—Baby Peggy with her Grebe Receiver.....	1
Drafting a New Radio Bill.....	7
The Superdyne Receiver, by C. D. Tuska.....	9
Reflex—the Ultimate Receiver, by Wm. J. Schnell.....	11
Central America Tunes In, by José Velasco.....	13
Selectivity, by M. C. Batsel.....	15
Introducing Bowden Washington.....	17
Choosing the Proper Tube.....	18
The Perfect Short Wave Receiver, by Wm. F. Diehl.....	19
Correspondence with Radio Topics Readers.....	21
Mail Planes Radio Equipped.....	23
Speeding up the Morse Code, by S. R. Winters.....	25
New Patents for the Month.....	27
Dry Batteries for "C" Circuits, by W. B. Schulte.....	29

### PUBLISHED MONTHLY BY RADIO TOPICS

Entered as second-class matter at the Postoffice at Oak Park, Ill., February 25, 1922,  
under the Act of Congress of March 3, 1879.

Business and Editorial Office at 1112 North Blvd., Oak Park, Ill.

Chicago Phone: Austin 9300.

New York Office, 240 Broadway

Copyright 1923, by Radio Topics



# Last Minute News

☐ Europe and our English cousins are getting closer every day now that radio has spanned the ocean. The recent tests in trans-Atlantic communication were entirely successful, due to the splendid co-operation of all concerned, and the enthusiastic replies from various parts of England to the American broadcasting stations will encourage them to greater efforts. Let the good work go on.

☐ The year 1923 marked many improvements in radio, not the least of which was the highly efficient vacuum tubes now on the market, which are operated with the least power expenditure. The new tubes are more durable, silent in operation and long lived. Now, if the cost will come down, the one big bugaboo of radio will have been eliminated.

☐ The Authors and Publishers' Society is still holding out against allowing the broadcasting of their music by the larger and most popular stations. Occasionally one hears some of their music being sent out by privately owned stations on a low wavelength, but the big stations seem to be getting along nicely without their stuff.

☐ In England the latest thing is illustrated radio talks. The lecture is broadcast from a central station, and lantern slides are used to illustrate the lectures.

☐ If there was any doubt in the minds of the skeptical about the popularity of radio it was completely dispelled by the attendance at the recent Chicago Radio Show.

☐ The wide demand for portable and self-contained receivers last year has somewhat abated during the winter months, but a good single-circuit regenerative outfit with detector and audio amplifier tube that will function over wide range will always be popular with autoists and campers.

☐ "It's an ill wind that blows nobody good" was clearly exemplified in the recent Japanese disaster. Radio was the only means of communication left with the wrecking of the telegraph and cable lines, and the world was advised promptly of the magnitude of the earthquake and rushed relief to the stricken.

☐ A concert by Boy Scouts from station KDKA, Pittsburgh, was recently relayed throughout England, despite atmospheric obstacles, and was clearly heard by the cheapest amateur sets, it is said.

☐ Radio has become a great boon to many unfortunates lying in hospitals or homes, breaking up the oppressing monotony of their days and nights, and in many cases improvement in physical and mental condition has resulted.

VOL. III

JANUARY, 1924

NO. 12

## RADIO TOPICS

*The National Radio Monthly*

FOUNDED 1921

PUBLISHED EVERY MONTH BY

RADIO TOPICS, PUBLISHERS

1112 NORTH BLVD., OAK PARK, ILLINOIS, U. S. A.

NANKO C. BOS, Managing Editor

J. RAY MURRAY, Editor

WILL M. HIGHT, Business Manager

Publishing and Editorial Offices

Chicago Phone: Austin 9300      Oak Park Phone: Oak Park 3200

RADIO TOPICS is on sale the 10th of preceding month. Text and advertising forms close the 22nd of second month preceding issue.

Twenty Cents the Copy From All Newsdealers. By Subscription: To the United States and Possessions, Cuba and Mexico, \$2.00 the Year. Remit by U. S. Money Order, Express Money Order, Check or by Draft, payable in U. S. Funds.  
To Canada—By Subscription, \$3.00 the Year. Single Copies 25 Cents—Canadian or U. S. Funds.

# Drafting New Radio Bill

SECRETARY HOOVER HARD AT WORK ON NEW MEASURE—NO CONFERENCE TO BE HELD THIS YEAR

**T**HE Commerce Department at Washington is now working on a tentative regulatory measure, based on the old White Bill, which is designed to help all interested in radio transmission and receiving.

Secretary Hoover announced, however, that there would be no general conference in Washington this year. He believes that a law can be drawn up by government officials without such a conference, as practically all points were covered by the suggestions offered by representatives of the several lines of radio work last year. Mr. Hoover stated conditions had not changed materially since last year's conference, except that the number of broadcasting stations had greatly increased.

**A** DELEGATION of radio interests, representing the press, amateurs, clubs, engineers, broadcasters and others, called upon President Coolidge and Secretary of Commerce, recently and urged that a general conference be called, but it was stated it was difficult with the large body of diversified interests in radio to do so. Early action on the new radio measure, however, is looked for and the bill will be introduced by Representative White of Maine, during the early part of the year.

The secretary stated he would receive any suggestions the various interests had in writing and they would be considered by officials now working out the provisions of the new bill.

## Courts to Regulate

Officials of the government point out that many difficult questions arise when regulatory legislation is attempted. Such questions as monopolistic control, it is believed, should be handled by courts under existing laws and not incorporated in radio legislation. The prohibition of operation by aliens, if injected into radio legislation, would tend to handicap American radio development commercially in foreign countries and could be regulated without being covered in a radio bill.

The question of whether or not radio is a public utility is not essentially necessary in a law which should be regulatory, it is believed. Some definite standards of operation and equipment, especially in the commercial fields must be included, however, it is asserted, so that secretaries of commerce will have some basis for their decisions.

Recently new interference problems have arisen over which the department has no control under existing laws. Complaints received report interference from regenerative or reradiating receiving sets, violet ray machines, electrical precipitating plants, bell-ringing magnetoes on telephone lines and leaking insulation on power transmission lines. Government regulations should, it is believed, give the department power to prevent such interference.

After the presentation of the tentative bill in the house, and its assignment to the merchant marine and fisheries committee, it is understood that public hearings will be held at which time all interests may appear to present their suggestions and recommendations.

## Canaries Sing Over Radio

Radio "fans" picked up WTAM on December 12, heard the birdies sing even though it was a dark and stormy night. Eight little yellow Rollers each took a turn before the microphone and "strutted their stuff."

The birds were furnished by exhibitors at the International Roller Canary Show, held in Cleveland the week of December 10. All were prize winners in some branch of Roller Canary-ing.

Vancouver Premier, judged to be the world's champion singer, was one of the "artists." Another was Lohengrin, 1922 champion, who left the show to become first canary of the land as a gift to Mrs. Calvin Coolidge. Whiz Bang Billie, a comer in bird circles was another of the vocalists.

Some of the birds took readily to the microphone. Others had to be coaxed with a violin before they condescended to pull out the tremulo stops and warble.

WTAM would like to hear from the "fans" who heard the birds.

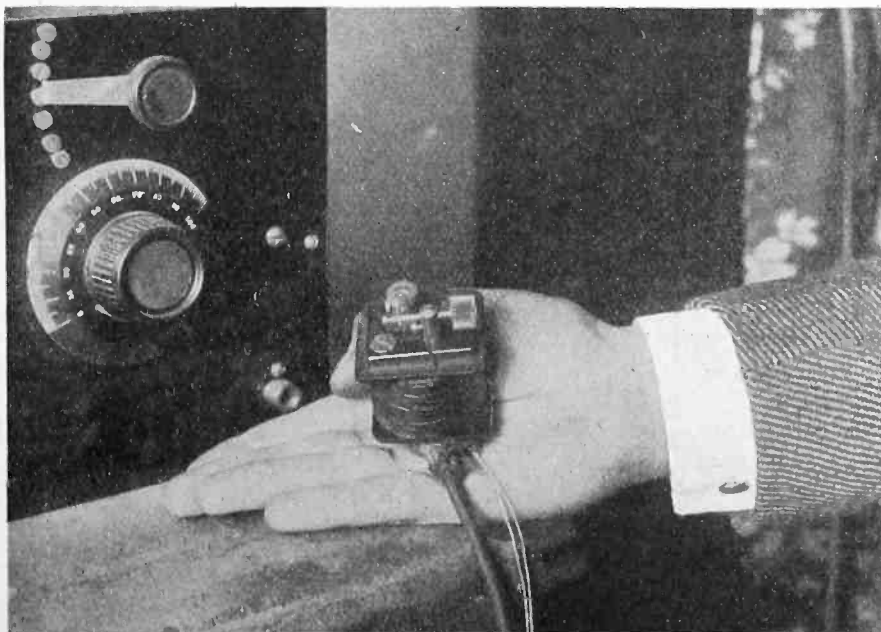

(Photo by Kadel & Herbert)

Another small receiving set which was entered at the recent Chicago Radio Show. This tiny crystal set was built by Wendall Kilmer of New York, and fits in the palm of the hand. It will receive efficiently over a range of 25 miles. An ordinary pin is used as a catswhisker.

## Novel Demonstration at Radio Show

**A** DEMONSTRATION board which graphically illustrated the factors affecting "B" battery current drain attracted considerable attention at the Philadelphia Radio Show, which closed November 17. The same board was moved to Chicago for the show there, and then on to Boston for the Boston show, December 3 to 8. The board was part of the exhibit of the National Carbon Company, and was manipulated by F. T. Bowditch, physicist, the associated company of the Union Carbide and Carbon Research Laboratories, Inc.

Just how much interest was shown in this battery demonstration may be imagined from the fact that the radio fans took away with them 20,000 National Carbon Company booklets describing battery operation, during the time the show was on. And the fans literally took them as the photograph shows. Each demonstration closed with the announcement that the new booklet, "How to Get Most Out of your 'B' Battery," might be had for the asking. Fans at once surged forward toward the booth, seizing the booklets the instant they came within arm's reach. One of these onslaughts is shown in the photograph, made during one evening at the show. The booklets rehearsed the information given by Mr. Bowditch during his talk and demonstration.

The demonstration board stood at one side of the booth and was constructed with a huge ammeter running across the top. As Mr. Bowditch explained the effects on battery life of the number of tubes, "B" battery voltage, use of a "C" battery, etc., needle of the ammeter swung backward and forward across the dial, clearly visible to the farthest corner of the crowd. The demonstrator was able to talk in a natural voice by means of the Western Electric Public Address System in front of the board.

Besides the demonstration board, the National Carbon booth contained two large display stands carried all the different types of Eveready Radio batteries, with large lettered cards explaining the use of each in different radio installations.

## Two Exhibits at Chicago Radio Show



Radio fans at Chicago Radio Show listening to lecture on "B" Battery practice. Twenty thousand booklets on "How to Get the Most Out of Your B Battery" were distributed the first day of the show.

There was also a new flashlight display case, in which were all the various kinds of flashlights manufactured by the National Carbon Company. Radio fans' attention was called to these by a card which pointed out that a flashlight was a necessary and valuable accessory in every radio set, in order that all connections might be clearly illuminated at an instant's notice while making adjustments within the dark cabinet. The display case was so arranged that on withdrawing a flashlight battery from a storage drawer underneath, the battery

came in automatic contact with a wire leading to a small bulb inside the case. The contact flashed a light from the bulb, illuminating the display and at the same time showing the customer that the battery was working properly.

In addition to Mr. Bowditch, the National Carbon Company was represented by G. C. Furness, manager of the Radio Department; A. M. Joralemon, sales manager, Radio Department; E. E. Horine, radio engineer, and E. Harold Boudwin, Philadelphia representative.

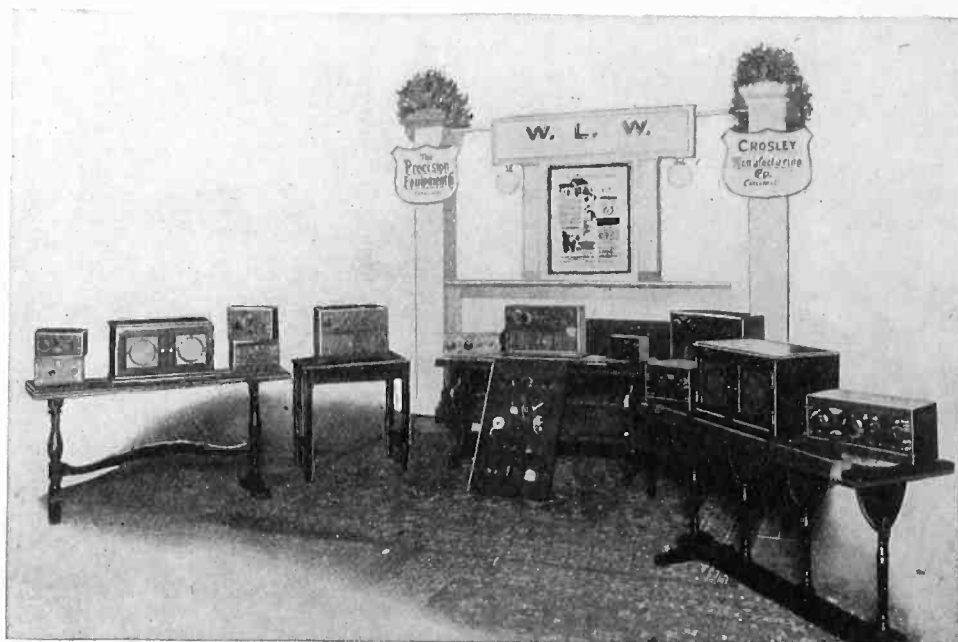

A general view of the Precision Equipment Co., Cincinnati, display, where many fans learned all about the Crosley Receivers and got acquainted with the man who owns Station WLW, Powel Crosley, Jr.



# The Superdyne Receiver

By C. D. TUSKA

President of the C. D. Tuska Company

THE Superdyne Receiver is a name which has been applied to a new receiving circuit. Almost a year ago Robert S. Miner of the C. D. Tuska Company started to work on a receiver which would give results which surpassed the regenerative receiver and the many radio frequency outfits which we had tested.

In seeking for this new "super" circuit, we investigated all of the latest circuits and every modification of regenerative, radio frequency and other circuits of which we had information. In order to acquaint you with some of the difficulties and problems, I am going to partially review the Vacuum Tube Circuits:

First—we have the usual Vacuum Tube circuit of straight detection. This type of circuit is illustrated by Figure "1" and is familiar to everyone. It detects at radio frequency and gives us an audio frequency impulse in the plate circuit.

The first improvement over this circuit was made by Armstrong, who, about 1914, conceived the idea of making the plate circuit resonant to the frequency of reception in the grid circuit. Although there are many modifications of the Armstrong feedback circuit, it may be considered as an inductance in the plate circuit, which can be tuned to the required frequency. Sometimes this inductance in the plate circuit is coupled to the grid circuit conductively or inductively, at other times the plate circuit is not coupled by any other means than the capacity of the tube; that is, the capacity which exists between filament, grid and plate, Fig. 2.

\* \* \*

The next attempt to improve the sensitivity of the receiving circuit lies in the efforts which have been made to develop a radio frequency amplifier that has one or more stages of vacuum tubes which are coupled together before the detector. These one or more stages are supposed to amplify the radio frequency so that the detector will receive the full benefit of its efficiency which increases approximately as the voltage squared. This system of amplification is not a difficult matter on long wavelengths where the vacuum tubes can be easily connected by a resistance method. In this method the efficiency per stage is very low and the resistance is very wasteful of B Battery voltages. However, in the case of the shorter wavelengths we encounter many difficulties.

The first and most important of these is tube capacity. At the short wavelengths or extreme high frequencies; i. e., wavelengths under 600 meters, we find that the capacity of the tube is so great that the radio frequency current tends to pass through the capacity rather than take the path which is required to operate the vacuum tube. There have been numerous

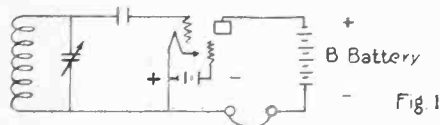

Fig 1

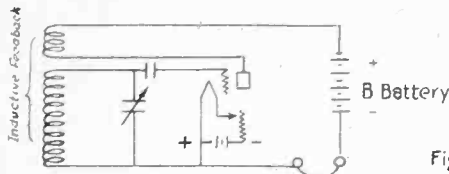

Fig 2

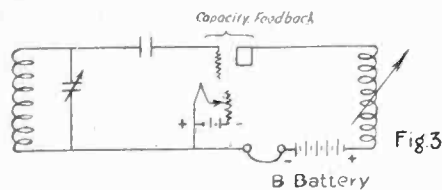

Fig 3

attempts made to overcome this capacity trouble, particularly in England, where special tubes were built having small elements. Special care was taken to bring the grid and plate leads out of the tube so as to eliminate capacity in the wiring. These tubes have greatly reduced capacity and have improved the radio frequency amplifying characteristics. Fig. 3.

However, in America we have had no such development work on tubes. One successful attempt at the solution was made by Armstrong, who employed the super-hetrodyne method; i. e., the method of converting the high frequency into low frequency, which could easily be handled with our market tubes. Using this type of circuit, we find that it is generally necessary to use at least eight vacuum tubes and there is more or less difficulty in the handling of such a sys-

tem by a novice. The amount of current required from the A Battery is a serious drawback and the high cost of tubes does not make the outfit any more attractive.

\* \* \*

Armstrong's later work consisted in the development of what he terms the "super-regeneration method." While this method seemed to offer all of the necessary benefits, in practice we find it extremely difficult to get satisfactory results in distant reception. Nearby signals were very loud, but distant reception was lacking.

The latest of all these various efforts is the Hazletine Neutrodyne Receiver. The circuit attempts to neutralize the feedback capacity in a radio frequency amplifier. While the circuit does perform well, it generally oscillates at some wavelengths when exactly in resonance and offers difficulties in tuning weak signals. (Fig. 4.)

This is a brief and rather hazy review of some of the efforts which have been made to produce the supersensitive receiver.

Mr. Miner, known to amateurs as 1RU, thought that the only trouble with radio frequency is that we do not get sufficient amplification per stage, and he decided to overcome this difficulty. He set about doing it in this way: First by locating the difficulties, then by overcoming them.

At the start we realized that there were two obvious troubles: First, the capacity feedback of the tube; second, the difficulty of securing a resonant plate circuit. The first attempt to produce a more sensitive receiver was somewhat along the lines of most of

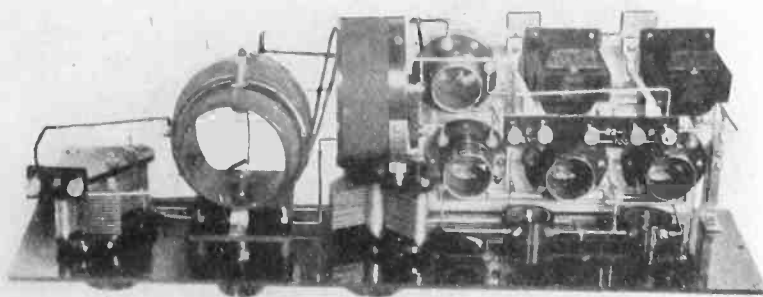

Fig. 7



Fig. 8

the radio frequency amplifiers. All of the various transformers were tried out and attempts were made to design special transformers. This was given up, as it was found difficult to get a transformer which would cover the band of wavelengths and give sufficient amplification per stage. We tried using tuneplate methods, but we found two things were inclined to happen: First, we did not get as much amplification as we did with one less tube in a regenerative outfit, and second, the ever-present tendency for the vacuum tube to oscillate as soon as the plate circuit approached resonance with the grid circuit spoiled the amplification. We attempted to overcome this difficulty by means of the usual stabilizer, which "QST" has so aptly termed "a lesser." Even using the stabilizer we found that it was most important to have a resonant plate circuit. One look at the voltage curve of a resonant circuit such as shown in Fig. 5 will immediately point out the advantages of curve "AB" over curve "CD." "AB" is the type of curve which we might expect with the resonant plate circuit, while "CD" is the sort of result which would probably be had with the transformer coupled amplifier.

\* \* \*

It was evident that we must use resonant circuits and it was further apparent that the minute we did use resonant circuits the tubes started to oscillate and spoiled everything. We were in a "vicious circle." The method which was used to overcome this difficulty surely seems obvious now but Mr. Miner can assure you that this was not the case a few months ago. All that is necessary to do is to put in the conventional Armstrong feedback but feed the energy back in the reverse direction or negatively. All that we have to do is give the circuit just enough negative feedback to offset the positive capacity feedback of the tube. This will stop oscillation and make it possible to secure absolute resonance between the grid and the plate circuits. Not only have we secured resonance but we have used the maximum impedance in the plate circuit which in turn means the biggest voltage impulse which we can hope to build up.

The Superdyne Circuit is shown in Fig. 6. "R" is the resonant circuit of the grid. "WC" is the resonant circuit of the plate while "XY" is the reverse feedback which stops oscillation. The detector is connected as shown. After we found what the possibilities were with this circuit we began to experiment, thinking that we could improve it by changing the constants. We went through all of the stages of increasing capacity and decreasing inductance as well as the reverse. We tried every sort of coupling and every conceivable manner of turns ratio. Hundreds of separate experiments indicated that the successful operation of the circuit depended to an extremely high degree in following these dimensions carefully.

Not only is it necessary to carefully follow the instructions about sizes of wire and dimensions but in addition you must be very cautious not to parallel the grid and the plate wires of

the radio frequency stage. These wires must be kept at right angles and as far apart as possible. If the reverse feedback coil is coupled too closely to the grid coil the capacity between the grid and plate windings exceeds the negative magnetic feedback and the set will not work. It is extremely important to avoid this trouble and here again we want to caution you to copy exactly the specifications we have outlined.

The dimensions and constants of the various coils and condensers are shown in the following table. If anyone is anxious to experiment with this circuit I want to take this opportunity to warn him of the absolute necessity of sticking to the dimensions, wire sizes, etc. We have not

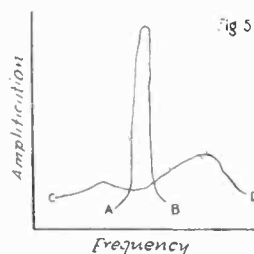
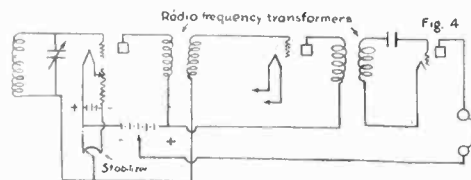

had very good success with reception on the detector, which is probably partly due to the capacity of the phones on the ungrounded circuit. If you intend operating with a small indoor antenna, ground the filaments and connect the antenna to the grid of the first tube, leaving out the antenna coupling turns. With this method, phones on the detector will probably be entirely satisfactory.

Secondary—Coil form, O. D. winding, 4 inches;  $1\frac{1}{4}$  inches; 42 turns; No. 22 D. S. C. wire; taps, 0.20.42; microhenries, 273.

Antenna—Over secondary; turns spaced,  $\frac{1}{4}$ ; 4 turns; No. 22 D. S. C. wire; taps, 0.4.

Tickler—Coil form,  $3\frac{3}{8}$  inches; O. D. winding, ball rotor; turns,  $18 \times 2-36$ ; No. 22 D. S. C. wire; taps, 0.36.

Plate reactance—Coil form, 4 inches; O. D. winding,  $1\frac{1}{4}$  inches; 46 turns; No. 22 D. S. C. wire; taps, 0.25.46; microhenries, 264.

Condenser (grid)—Coil form, O. D. winding, Tuska Type 271; turns, 23 plates; wire, maximum capacity; taps, .00482.

Condenser (Plate)—Coil form, O. D. winding, Tuska Type 271; turns, 23 plates; wire, maximum capacity; taps, .00482.

Wavelength range (approximate)—176-358; 310-660.

Now a word about results. First—the maximum results can be obtained after the operator has learned how to carefully adjust the circuits. It is not possible to get these results until one has had some experience in tuning faint signals.

The astonishing part about this outfit is that it operates without an antenna and gives signals of sufficient intensity to be heard through the use of a loud speaker. In Hartford, Con-

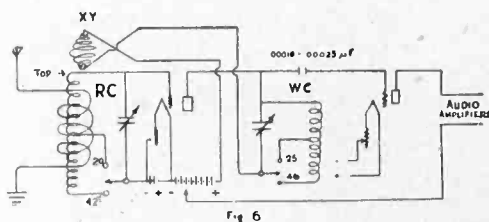

necticut, without the use of an antenna or loop or capacity of any sort, other than the usual ground connection, we have repeatedly on a loud speaker heard broadcasts from Chicago, Davenport, Kansas City and stations nearer to us. In attempting to compare the outfit with some of the sensitive sets on the market, we went to Washington and ran a series of tests.

First—a constant artificial source of power was set up. This was tuned on a regenerative receiver and the audibility measured around 50. With the same power, the same tubes, batteries, etc., the Superdyne receiver showed an audibility of over 200. The same two outfits were tried under similar conditions with a broadcasting station as the source of power. Here the regenerative receiver showed audibility of about 60 while under corresponding conditions the Superdyne receiver showed an audibility of 10,000 which was the end of the meter.

The next test was of a more practical nature. Here we compared the Superdyne receiver under actual receiving conditions with the naval six-tube Universal radio frequency amplifier. The signals with the four-tube Superdyne were probably three to four times louder than with the six tubes on the navy amplifier. The last experiment was the most astonishing of all. In this test we compared the four-tube Superdyne with the eight tubes on a Super-hetrodyne receiver. Some of the signals on the Super-hetrodyne surpassed this new circuit while in other cases the Superdyne exceeded the Super-hetrodyne. Taken all in all, and being very conservative, the best we could say for the Super-hetrodyne was that the signals may have been slightly louder using the eight tubes against our four.

A word about the operation. In operating this circuit we have found that it is highly desirable to adjust the plate circuit for the wavelength to be received, then operate the reverse feedback coil which we have called "stabilizer," and the grid circuit in exactly the same manner as one operates a regenerative receiver. By careful adjusting the reverse feedback against the positive capacity feedback one can get astounding degrees of amplification. We figured out that the voltage amplification per stage probably ran in the neighborhood of 100 times. Of course, it is a well-known fact that one tube of radio frequency regeneration of the old style rarely exceeded a voltage amplification of eight or nine times.

In order to simplify the operation we have omitted any tuned antenna circuit and simply used four turns of wire which are closely coupled to the grid circuit. This impulse excitation method of tuning seems to be sufficiently selective, which is probably due to the selectivity of the two resonant circuits.

While the Tuska Company expects to market complete Superdyne sets, we shall be glad to assist you if you are going to build your own. I should consider it a great favor if you would keep me personally advised as to what sort of success you have with it.



# Reflex—The Ultimate Receiver

By WILLIAM J. SCHNELL

*Radio Engineering Staff, Electrical Research Laboratories, Chicago*

**T**O the average radio enthusiast a certain amount of interest is derived from adventures in building and operating his own receivers. Satisfying as this may be, many evidence a particular desire to understand the whys and wherefores of the functioning of their receivers. To the prospective builder also appeals the knowledge of the characteristics of various receivers in order to better equip him in his selection of the circuit for his receiver. It is to these particular classes of the radio public to which this article is particularly directed.

The principle of the reflex circuit depends on the ability of a three electrode vacuum tube to permit currents of different frequencies to pass through it at the same time. The frequency of the currents induced in a radio antenna system are very rapid in their cyclic changes, varying in value from about 500 to 1,000 kilo-cycles per second, depending on wavelengths. This incident current in the antenna system is generally termed the radio frequency current. It is not possible to cause such high frequency currents in this rapid changing form to actuate directly on a device to convert electrical current variations into sound waves (receivers). In a reflex system these radio frequency currents are usually simplified to increase their intensity before impressing them on the rectifier or detector, which converts these high frequency currents into currents of audible frequency. After rectification these currents are then amplified as were the radio currents by a three-electrode vacuum tube. Here lies the difference in and particular advantage of the reflex system over other systems.

\* \* \*

In other systems after rectification the rectified radio or audio currents are amplified by additional tubes for this purpose. In a reflex system before these input radio frequency currents are rectified they are reimpressed back on the tubes which amplified them at radio frequency, and when rectified are re-amplified at audio fre-

quency before being passed on to the receivers or loud speaker to be converted to sound waves.

If properly designed and built, more than vacuum tube economy can be secured from reflexing.

There are a number of methods of utilizing the reflex principle among which are the progressive plural tube reflex wherein action proceeds from the in-put to the out-put tube in direct progression and where the reflex action is performed in more than one tube. Then there is the so-called inverse duplex system wherein the reflex action is not tube progressive, but is inverted back toward the in-put tubes. In the Erla circuits the reflex action is progressive from the input, but is only utilized in one tube. In the other above mentioned systems the reflex feature is made to actuate in more than one stage or tube. Due to the complexity of controlling radio frequency it is not possible to successfully stabilize a system wherein the reflex action is progressive from the one stage. It is not a matter of balancing the loads in the various tubes, as it can be readily shown that the loads caused by any audio signals on the tubes in these circuits are never such that the few micro-watts of radio signals addi-

tionally impressed upon them would overload them as has been many times stated.

In the systems wherein the reflex action has been extended to more than one stage it would be necessary to add considerable adjustments to control the currents in their relations to one another in the various circuits before anything like successful operation would be secured. Due to these complications such systems are not considered practical.

In all reflex systems radio frequency amplification is employed. In general there are practically two forms of using vacuum tubes as radio frequency amplifiers, i. e., the coupling transformers may be either tunable or the tuning of these transformers is fixed. The tunable type transformers are so designed that they may be tuned usually by a variable condenser. In the other type the transformers represent a certain tuning over a certain range without tuning. The latter are "broad" and make for unselective reception. With a great number of broadcasters operating over a considerable wave band, selectivity is of prime importance. The feasibility of securing anything like selectivity from such radio frequency coupling trans-

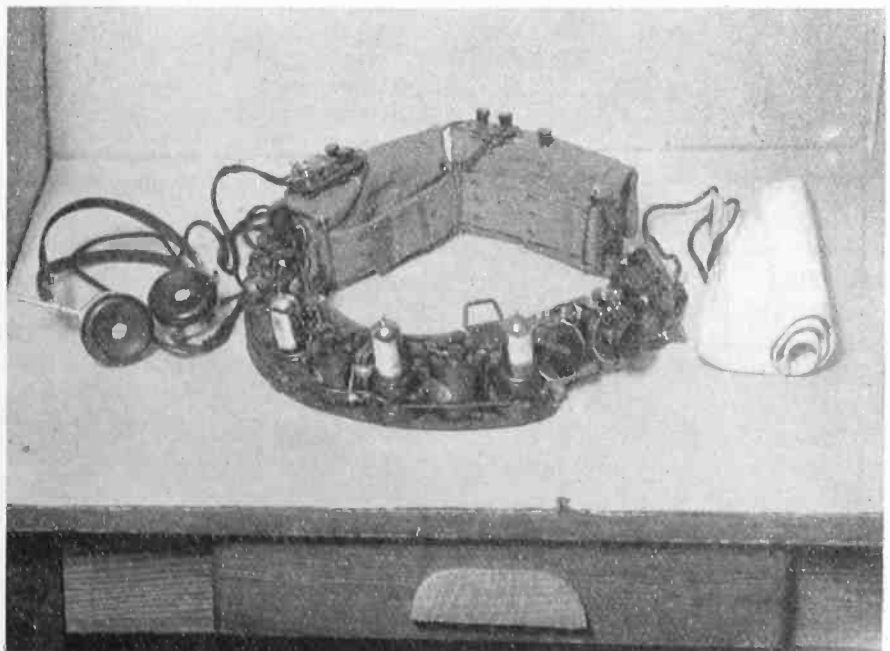

Here's a radio set built for hikers. It fastens around the waist and was built by Henry Farkoun, Brooklyn, N. Y. It consists of three tubes and the usual A and B batteries. The antenna wire is enclosed in the canvas which can be rolled up like a window shade when not in use. —(Gilman Service.)

formers as the tuned type is likewise only too well known by those who have attempted it. Therefore, it is imperative that if selectivity is to be had where radio frequency amplification is employed the coupling transformers in such an amplifier must permit tuning adjustment by a variable tuning device such as a variable condenser. Because the transformer is actually tuned to the signal with this type of radio frequency amplification, not only great selectivity is obtained, but greater amplification is likewise secured. No transformer which is designed to have fixed tuning can successfully operate either in this form or even if a variable tuning device is added to it, because this design will not permit of it. Therefore, the radio frequency stages should consist of transformers which permit tuning.

\* \* \*

Either a vacuum tube, two or three electrode, or any of the many forms of crystal rectifiers of high frequency currents can be used a rectifier, we are told. However, in a reflex circuit, due to the particular location in the circuit and inherent characteristics of the detector, a crystal rectifier will be more satisfactory. By the use of the proper crystal rectifier an excellent controlling effect on the stability of the entire circuit may be had. This feature is not generally known, but is demonstrated in the stability of the circuits using this form of a detector. This point has been brought out time and again in laboratory analysis.

Not every crystal rectifier which might possess high rectifying properties will be found the best for this purpose, due to the fact that the crystal can be made to provide a stabilizing effect on the reflex action of the circuit. The fixed type of crystal naturally requiring no adjustment, if correctly designed, affords the best form of rectifier for the reflex circuit.

Another point of interest which was first announced by the Electrical Research Laboratories in their development of reflex circuits and likewise not generally known is the fact that not any and every audio transformer can be used in a reflex circuit. In a reflex circuit the audio transformer is associated with the radio frequency currents of the circuits and requires a design and construction differing from the regular audio transformer.



Miss Louise Koetter, contralto soloist of the Presbyterian Church of the Covenant, whose voice is heard every Sunday from Station WLW, Cincinnati. Miss Koetter recently sang "A Pickaninny Lullaby," a new number written by Frederick D. Smith, studio director of WLW.

In the foregoing I have shown the action of the reflex principle and pointed out the various methods of performance and the advantages and disadvantages of each. I will now summarize the findings into the requirements of a reflex receiver for practical, successful and efficient operation:

1. The reflex action should not be extended to more than one tube for stable operation.
2. Straight radio or straight audio added is desirable, but not more reflexing stages.
3. The radio frequency amplifier should be of such construction as to permit of variable tuning, if selectivity and maximum amplifier efficiency is to be obtained.
4. A crystal rectifier of the correct design will afford the most efficient rectifier for the circuit.
5. The audio transformer is of prime importance in the maximum of reflex action.

The circuits developed by the Electrical Research Laboratories offer various choices to the radio enthusiasts and at the same time permit of the maximum requirements as listed above. There have been three reflex circuits so far released by the Electrical Research Laboratories and to secure success for these circuits the design of the exacting apparatus for these circuits was also developed.

\* \* \*

These circuits comprise, one, two and three tube combinations.

The one tube circuit consists of one stage of radio frequency amplification, one stage of reflexed radio frequency and one stage of audio amplification wherein a crystal is utilized for rectification and stability. This combination affords the maximum of satisfaction obtainable from one tube—affording loud speaker operation on all local signals and likewise ample volume on distant signals.

The two-tube circuit consists of one stage of straight radio frequency amplification, one stage radio frequency tuned and one stage of reflexed radio frequency with one stage of reflexed audio frequency amplification wherein a crystal is employed for rectification. High selectivity sensitiveness and volume are obtainable from this combination. The three-tube circuit is the same as the two-tube circuit with the addition of one stage of straight audio amplification. This affords all the advantages of the two-tube circuit as regards selectivity and sensitiveness, with the addition of surplus volume.

Tube for tube greater efficiency is possible with these circuits than in any other combination. There is no question but that the reflex principle is in line with the progress towards the ultimate receiver.

## Message Travels 12,000 Miles

Douglas Rigney, General Manager of A. H. Grebe & Co., Inc., Richmond Hill, N. Y., received the following telegram on Tuesday, November 27:

Avalon, Cal., Douglas Rigney:

Using Grebe 13 broke all speed records early today. Received message for Mix from Boyd Phelps Station one have X-Ray Hartford, Connecticut, direct. Transmitted direct to Mix and returned answer to Hartford in five minutes and six seconds.

Major Lawrence Mott.

Major Mott is well known to the amateur fraternity. His is the first U. S. Pacific Coast Amateur Station to conduct a two-way communication with the "Bowdoin."

Major Mott copied WNP two hours on October 25. On November 18 Major Mott worked WNP directly for one hour.



# An Interesting Letter from a Real Fan Central America Tunes In

By JOSÉ VELASCO

**A**LTHOUGH born in Santa Ana, the second largest city in the Republic of El Salvador, and having Spanish blood, I truly love the United States of America as I love my own country and greatly admire the advancement made in radio the last few years by American scientists.

For a decade I have been a "dyed in the wool" radio amateur and have burnt midnight oil listening in with my radio receiver. Last year, to be exact, on November 2, I heard for the first time a radio-phonograph concert as it was being broadcast from station KDKA and, Oh Boy! I was tickled to death not only because **HERE** in my home town I was listening to concerts from the States, but also because I was the second to do this in my country.

Herewith is a picture of my first set. At that time I used three stages of radio frequency amplification, detector and one stage of audio frequency amplification, using head 'phones. The stations heard up to the day I am writing (November 10) are:

CYB—Mexico City.  
 PWX—Habana, Cuba.  
 6KW—Tuinicu, Cuba.  
 WBAP—Fort Worth, Texas.  
 WKAL—Orange, Texas.  
 WFAA—Dallas, Texas.  
 WOAI—San Antonio, Texas.  
 WHAB—Galveston, Texas.  
 WJAD—Waco, Texas.  
 WEAY—Houston, Texas.  
 WOQ—Kansas City, Mo.  
 WHB—Kansas City, Mo.

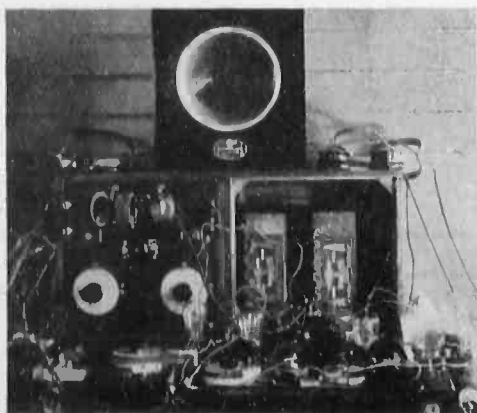

The old reliable receiving set used in experimental work. It employed a honeycomb coil tuner.



José Velasco and a general view of the rear of his receiver. Note the aluminum shield.

WDAF—Kansas City, Mo.  
 KSD—St. Louis, Mo.  
 WKY—Oklahoma City, Okla.  
 WDAJ—College Park, Ga.  
 WGM—Atlanta, Ga.  
 WSB—Atlanta, Ga.  
 WBT—Charlotte, N. C.  
 WOAC—Lima, Ohio.  
 WJAX—Cleveland, Ohio.  
 WOC—Davenport, Iowa.  
 WAAP—Wichita, Kan.  
 WSY—Birmingham, Ala.  
 WMC—Memphis, Tenn.  
 WOS—Jefferson City, Mo.  
 WJAZ—Chicago, Ill.  
 WRC—Washington, D. C.  
 WHAS—Louisville, Ky.  
 WMAT—Duluth, Minn.  
 WCX—Detroit, Mich.  
 WWJ—Detroit, Mich.  
 WFI—Philadelphia, Pa.  
 KDKA—East Pittsburgh, Pa.  
 KHJ—Los Angeles, Cal.  
 KFI—Los Angeles, Cal.  
 KPO—San Francisco, Cal.  
 WJZ—Newark, N. J.  
 WOR—Newark, N. J.  
 WBAY—New York City, N. Y.  
 WEA—New York City, N. Y.  
 WJY—New York City, N. Y.  
 WJZ—New York City, N. Y.  
 WGY—Schenectady, N. Y.  
 WHAZ—Troy, N. Y.  
 CFCN—Calgary, Alberta, Canada.  
 WDAR—Philadelphia, Pa.  
 WTAM—Cleveland, Ohio.

WJZ listed in Newark, New Jersey, was the old Westinghouse station, while the same listed in New York City, N. Y., is the new Radio Corporation of America station; WKAL is now cancelled.

\* \* \*

My record DX work was done this last February when I heard over the loud speaker, seventeen

consecutive nights station CFCN broadcasting jazz music from a cabaret very loud and perfectly clear. I think it is a good performance for a home-made receiving set and I now can say that my receiver has stood the acid test for DX reception OK.

Have heard, too, a few other stations but I haven't got their call letters due to spark and static interference. All the above stations listed here can be heard any time when they are on the air after 5:30 p. m. Central Standard Time and when static is not going full blast, as you should know the tropical region is the very home of old man QRN and during summer time when you turn on the loud speaker it sounds like a boiler factory, and it is impossible to do DX work; with exception of CFCN all stations can be heard very regularly during the cold nights.

Part of my present station equipment consists of an inverted "L" type aerial, 70 feet long the flat top, 35 feet high at both ends and 30 feet lead-in wire. I use copper plates and wire buried under wet earth (not dry—here everything is wet), as the ground connection.

The receiver proper which I have just finished, consists of a three stage radio frequency amplifier (two tubes using transformer coupling and the third uses the tuned plate system of coupling) detector, one stage of audio fre-

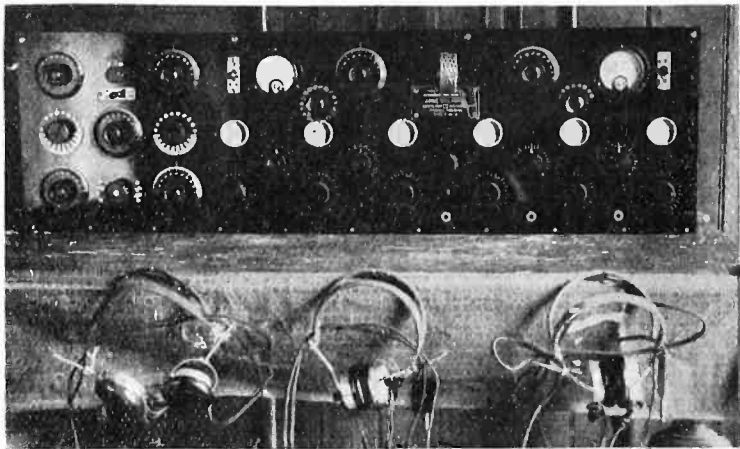

Another view of Mr. Velasco's receiver with which he has heard many American stations.

quency amplification and a one stage power amplifier.

Radiotrone UV-201A are used as R. F. amplifiers, Cunningham C-301A for the A. F. amplifier and Western Electric Company 216-A for the power amplifier; the plates of the R. F. amplifier have 80 volts also the A. F. amplifier while the power amplifier has 110. Willard "A" and "B" storage batteries are used exclusively, one separate set for the R. F. amplifier and detector and the other for the A. F. and power amplifier. Charging unit consists of a full wave bulb rectifier for "B" batts. and a half-wave bulb rectifier for "A" batts; a separate switchboard is used to control charging current and connect and disconnect batteries from rectifiers and receiver without disturbing any wire whatsoever.

\* \* \*

Now just a few words regarding my experiments with my sets.

First of all, I want to state that I have had wonderful success with low and short receiving aerials, with this type I don't have very much spark and static interference as the receiver tunes very sharp and is really selective, and I get very good signals, loud and clear, and a marked reduction of a. c. hum and static. Sometimes I have been able to use a loop aerial but only using phones.

The principal and most important features of my receiver are: First, the third stage of radio-frequency amplification which uses the tuned plate system of coupling. I have tried other amplifiers and have found this combination truly good for elimination of interference of all kinds, awfully sharp tuning, ultra-sensitiveness and a marked ability to bring in far away station's signals. Second, and last, but not least, amplify uniformly,

powerfully and clearly on different wavelengths. Of interest too is the audio frequency and power amplifier which amplifies speech and music with very good tonal qualities due to the circuit used.

In the near future I hope to be able to publish the complete hook-up of my receiving station with the only idea in mind that maybe somebody would like to make something along these lines.

Before I finish I want to add my deep and great appreciation for the American amateur fraternity and for one of the very best among magazines—RADIO TOPICS.

### Dishpan Makes Good Antenna

A radio receiver set which, with a dishpan for an antenna, catches broadcasts from a 500-watt station 1,400 miles away, has been developed by Bowden Washington of Minneapolis, Minn., it was announced recently by the Cutting & Washington Radio Corporation.

The receiver, the result of two and a half years of laboratory efforts, works on a somewhat new principle, termed cascade regeneration, which renders extremely small antennae highly effective.

With four UV-199's and a dishpan on a chair for an antenna, and another on the floor directly beneath it for a "counterpoise," signals from a 500-watt Western Electric transmitter in Dallas, Texas, were heard 1,400 miles distant on a loud speaker with such intensity as to be unpleasant. The receiver works equally well with a fly screen, a 6-foot wire, a magnavox horn or any small body of metal for an antenna, the announcement said.

A 6-foot steel fishing rod was stuck up for an antenna between the cushions of a large touring car

and signals from WLAG station, Minneapolis, at 20 to 30 miles could be heard for several hundred yards at a time while the car was in motion. The receiver is also extremely selective, distant stations having been received through broadcasts from the Cutting & Washington station while the receiver was located but 400 yards from the C. & W. station.

Washington is the designer of seven large commercial radio stations in the United States, including WSA, East Hampton, L. I., the most powerful spark marine station in the world, and during the war designed radio apparatus for the U. S. Navy and allied governments. He also gained scientific recognition as a photographer of radio waves.

### WTAM Heard in England

THE new high powered broadcasting station, WTAM, in Cleveland, Ohio, is rapidly gaining a reputation for long distance transmission, the latest evidence coming in the form of a letter from a listener in England.

Although a number of the larger broadcasting stations recently endeavored to bridge the Atlantic during National Radio Week, WTAM, according to the letter was heard in England before any special efforts were made in trans-Atlantic broadcasting.

The English radio "fan" who wrote the letter, Thomas E. Hamblett, St. Helen's, Lancastershire, stated that he heard the Willard Company's station quite clearly broadcasting its program on Wednesday evening, November 21.

He picked up WTAM at 3:48 a. m., London time, which is five hours earlier than New York time, and heard the remainder of the Willard program with practically no interference until the station signed off at 4:13 a. m., London time. His letter stated that his reception of "The Lost Chord," sung by the Amphion Male Quartette was almost perfect. Hamblett's set is one of his own assembly, using one stage of radio frequency and detector tube. His aerial, according to his letter consists of a single wire antenna 100 feet long and 33 feet high.

A number of other applause letters have been received from foreign countries within the two months this station operated by the Willard Storage Battery Company.



# SELECTIVITY

By M. C. BATSEL

*Radio Engineer, Westinghouse Electric & Mfg. Company*

**T**HERE are between five and six hundred broadcasting stations in the United States. In every locality it is possible to choose from several stations operating at the same time. In order to do this we should know some of the principles underlying selectivity, or the power of choice, which permits us to tune out the stations operating on wave lengths stations operating on wavelengths differing from the wavelength of the station we wish to hear.

An electric current is caused to flow in a receiver by the waves from the transmitting station. If the receiver is tuned to the same wavelength as the transmitter this current is of maximum strength and the sounds received are, therefore, loudest. Currents due to the waves of other frequency or wavelengths are relatively much weaker. The relative strength of the currents received from two stations of equal power and at equal distances from the receiver, when the receiver is tuned to one of the transmitting stations, depends on the difference in the wavelengths, the design of the receiving instruments, and the receiving antenna.

\* \* \*

By properly proportioning the inductance and the capacity of a circuit, the ratio of the current received on the wavelength for which it is tuned to that of other wavelengths may be made very great. The use of regeneration still further increases this ratio. The principles just stated govern the design of practically all receiving sets. If there is no powerful station in the immediate vicinity a properly designed single circuit regenerative receiver used with an efficient aerial will select the desired station and tune out all other stations that can be tuned out by any receiver capable of receiving music without destroying its quality. Two stations that are so nearly on the same wavelength that a sustained note or howl is heard cannot be separated by any known

method of tuning so that the satisfactory reception of music and speech is possible. If the tuning is made so sharp that one of the stations can be selected, all notes in the music of a pitch equal to or higher than the note heard, due to the interfering waves, will be tuned out. Therefore, it is evident that the only remedy for this condition is an assignment of wavelengths that will prevent two or more stations from transmitting at the same time on wavelengths that will produce such interference.

If there are two powerful broadcasting stations in the vicinity and neither can be received without interference from the other one, it is advisable to use a small antenna. Very often an indoor antenna of small wire concealed by a picture molding will be entirely satisfactory and does not require lightning protection, as it is indoors. If this very small antenna is not sufficient, an antenna may be used consisting of a single wire strung in the attic. If the small antenna and a single circuit regenerative receiver are used, the sensitivity of the system is in general only slightly less than when using a large antenna, and the strength of the interference is reduced in proportion to the effective height of the antenna. When using a small antenna the adjustments for tuning and regeneration must be made more accurately in order to bring in weak stations. A very satisfactory and convenient arrangement of antennae is to install a small indoor antenna and another outdoor antenna consisting of a single wire from 50 to 125 feet long with the horizontal span from 25 to 40 feet from the earth. The outdoor antenna should be clear of wires and the metal frame work of buildings. When there is interference from a nearby station, the small antenna can be used to advantage. When there is no interference the large antenna will make it possible to tune in weak stations more quickly and without such critical adjustments of the tuning and regeneration. The

very small antenna is practical only when regeneration is employed or when several additional tubes are used for radio frequency amplification.

\* \* \*

More complicated receivers can be used with large antennae to obtain a greater degree of freedom from interference by nearby stations, but the adjustments become troublesome and annoying to the unskilled operator. The proper adjustment of the more complicated circuits requires considerable time even when performed by an expert operator.

There is no doubt that the nearest high powered broadcasting station can render better service than can the station at a great distance, because of fading and atmospheric disturbances. If the reception of very weak stations is not attempted while the more powerful or nearby stations are operating, the small antenna and regenerative receiver will be found to meet all requirements.

If the small antenna with the single tuned circuit regenerative receiver is not preferred for eliminating interference, a receiver with coupled tuned circuits may be used for reducing the interference from a very powerful station. This type of receiver may be made by adding an additional tuner for the antenna circuit and placing it near the regenerative tuner. This additional tuner consists of an adjustable circuit made up of a variable inductance and a variable condenser. The antenna and ground connections on the regenerative tuner are connected together to form a closed circuit. The coupling is controlled by relative positions of the coils in the tuners.

\* \* \*

A more convenient method of reducing interference from one station is to connect a circuit tuned to the interfering station between the antenna and ground terminals of the receiver. This circuit will pass the current due to the interfering station to ground and if the circuit has considerable inductance and a small capacity the desired signals are not noticeably weak-

ened. The operation of the tuner is not complicated so much as it is when the two circuits must be adjusted to tune to a station. When the tuned by-pass circuit has been adjusted to eliminate the interference, it requires no further attention.

These coupled tuned and by-pass circuits will assist in receiving distant stations when the local stations are operating; but the simplest arrangement and a very satisfactory one for receiving one or several local broadcasting stations or one of the more powerful distant stations is the small indoor antenna.

### New Trans-Atlantic Records

During National Radio Week, November 25 to December 1, a series of trans-Atlantic tests were conducted between the various high power radiophone stations in the United States and those in Great Britain.

The British fans were obliged to stay up until the small hours of the morning, as the tests were made at 10 p. m. United States eastern time. But the epoch-making results which followed their efforts well repaid them for the loss of sleep.

On Saturday evening, December 1, the first successful two-way trans-oceanic radiophone communication in history was accomplished through the joint co-operation of the American and British stations, Radio Broadcast Magazine, the National Association of Broadcasters, and last but not least, the Broadcast Listeners of both countries.

Eight American stations and eight British stations participated, and listeners were well posted as to wavelengths, etc. Transmission was in five-minute periods, with five-minute intermission for replies, and covered in all a period of one-half hour.

American listeners had the pleasure of hearing their British neighbors reply to the transmission from the U. S. A. Aberdeen, Scotland, Station 2BD, on their last message reported that WOC, Davenport, Iowa, with whom they were scheduled to work, was being heard in and around the city of Aberdeen with little difficulty.

Old Father Time had better hire a few more stenographers if he intends to record all the radio history that is being made these days.

## A New Built-in Loud Speaker and 3-Tube Receiver

**A** BEAUTIFUL piece of furniture containing a remarkable efficient and selective three-tube receiver with built-in loud speaker is now found in the Ace 3-C Consolette made by the Precision Equipment Company, Cincinnati.

This type of receiver appeals particularly to the ladies on account of its being completely self-contained. Unsightly wires, batteries and other accessories are hidden from view. For range and volume it is all that can be desired.

Crosley Type "D" Condenser, which is part of the equipment, permits remarkably sharp tuning, enabling you to pick up distant stations through local broadcasting. We cannot comment too much upon the wonderful selectivity of this receiver. Of course, this set operates more efficiently on an out-of-door antenna, although excellent results can be obtained from a comparatively short antenna under average conditions. A single wire run along the ceiling or floor for a distance of from thirty to forty feet, will,

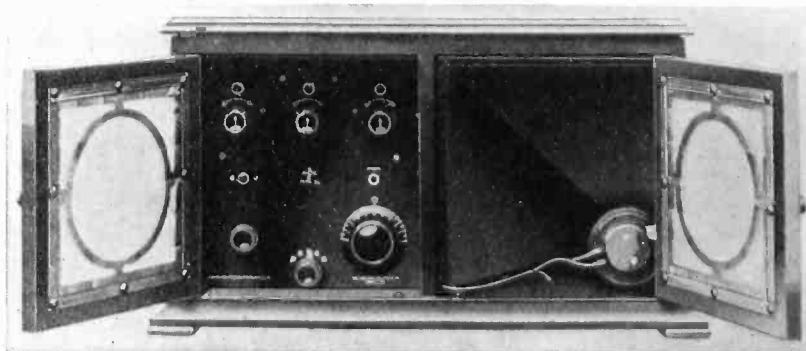

The Ace "3" Consolette, manufactured by the Precision Equipment Company, Cincinnati, made especially to appeal to the ladies.

It is so simple that a child can tune it and bring in distant stations clear and loud.

A stand is provided if desired at an additional cost of \$25, making a complete self-contained radio receiver of the floor type. The stand is designed to match perfectly the Consolette.

This is a three-tube Armstrong regenerative receiver, containing the new VARIND basket weave variable inductance. This unit is wonderfully selective and the

under most conditions, serve as a very satisfactory antenna for long distance reception. This is due to the wonderful efficiency of this receiver, which enables it to function on very weak signals collected by even a moderately inefficient antenna.

The size of the cabinet is 13 $\frac{5}{8}$  inches high, 23 inches wide and 13 $\frac{5}{8}$  inches deep. It is made of solid mahogany beautifully rubbed, piano finish. It is sold for \$125.

The set is provided with a phone jack to plug in head phones for tuning, using two tubes. When the plug is removed the three tubes are automatically connected to the loud speaker.

### Johannesburg Has Station

Completion of a large broadcasting station at Johannesburg, South Africa, will be accomplished soon after January 1, 1924, according to Consul G. K. Donald of that city. An increasing demand for radio sets is expected to follow.

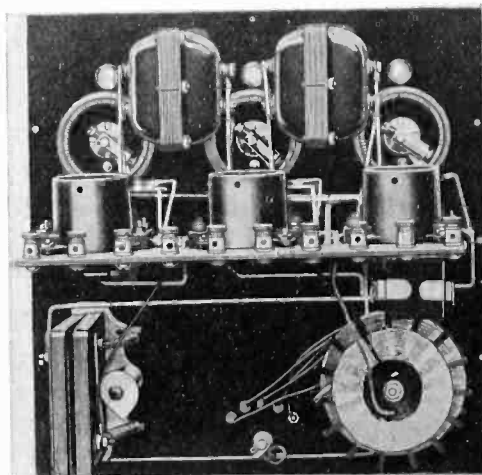

Another view of the Ace "3"—rear view of panel.

## Introducing Bowden Washington

Builder of Broad-  
casting and Re-  
ceiving Stations.

**R**ADIO engineers and fans recognize in Bowden Washington, vice-president and chief engineer of the Cutting & Washington Radio Corporation, a practical builder of both radio broadcasting and receiving stations.

He started his career in 1903 and for some years also adventured in many parts of the western hemisphere. In 1913 he built two then large radio stations in Mexico for Francisco Villa. The next year he was employed by Harvard University as a radio engineer and shortly afterwards, with Dr. Fulton Cutting, who now maintains laboratories in New York, developed the second successful transmitter to be commercially used—the first being that of Marconi. He next jumped into the public notice as a photographer of radio waves.

Before the United States got into the war, Washington designed and built radio apparatus for the Russian, French and British governments, as well as the merchant marine of a dozen countries. When the United States declared war, he designed and built radio apparatus for the United States navy, at one time having charge as a naval officer of the apparatus of 350 destroyers. He was also an aide to Rear-Admiral Robertson and on the staff of the Commander-in-Chief.

After the war, the Cutting & Washington Radio Corporation moved to New York, where at East Hampton, L. I., Washington built WSA, the most powerful spark marine station in the world. In 1920 the C. & W. combined with the Independent Wireless Telegraph, having a marine business of about 900 ships, Washington becoming chief engineer. In 1920 Washington became convinced that the greatest future of radio lay in the broadcasting field, and the C. & W. pulled out of Independent and was later established as the Cutting & Washington Radio Corporation, Minneapolis, Minn. Washington is the designer of the Cutting & Washington receiving sets.

He is a Fellow of the Institute of Radio Engineers, member of the American Institute of Electrical Engineers, member of the U. S. Naval Institute; associate member of the American Society of Naval Architects and Marine Engineers, member of the Standardization Committee I. R. E., a director of the National Association of Broadcasters, and a member of the Radio Committee A. I. E. E.



**Bowden Washington**  
Vice-President and Chief Engineer Cutting &  
Washington Radio Corp.



# Choosing the Proper Tube

**T**HE General Electric Company manufactures for the Radio Corporation of America three popular types of receiving tubes. These are Radiotrons UV-199, UV-200 and UV-201A. These tubes cannot be used interchangeably and each has a distinctive field of usefulness.

The choice of a tube to use for a particular purpose depends in general upon three main considerations:

(1) The purpose for which the set is to be used:

(a) Broadcast listening for the enjoyment of entertainment programs.

(b) Experimentation on apparatus and circuits.

(c) Long distance code reception.

(2) The type of set in which the tube is to be used; that is, the electrical circuits involved, number of tubes used and whether a loud speaker is included in the equipment.

(3) Whether storage batteries, No. 6 dry cells or flashlight dry cells are to be used for filament operation.

## The Radiotron UV-199

This tube requires a minimum of filament energy. In fact, it uses only .18 of a watt. The bulb is of small size and a special base and socket suitable for such a small tube are used. On account of the small size of this tube the capacity between electrodes is lower than in either of the other tubes.

This tube is particularly suited for portable sets in which it is necessary or desirable to use flashlight cells for filament operation.

It is recommended for sets in which there are three tubes or more and where dry cells only are available for filament operation.

For self-contained sets it is also very desirable because all of the necessary batteries can be placed in the cabinet with the rest of the equipment.

The small electrical capacity between the electrodes makes it a very satisfactory tube for radio frequency amplification.

## No Critical Adjustment

This tube does not require critical adjustment of plate voltage and tapped plate batteries are not necessary, whether the tube is used as a detector or as an amplifier. (Add "c" battery data same as UV-201-A except omit 120 volts).

The radiotron UV-200 is particularly desirable for the skilled radio experimenter, interested in code work and reception over very great distances. It is not suitable for dry cell operation because the filament requires one ampere at five volts.

Its action as a detector is very critical in respect to filament voltage and plate voltage. Its action as a detector is not as uniform between different tubes of the same type or as constant in any one tube as in the case of the high vacuum tubes UV-199 or UV-201A.

It is very sensitive to weak signals, especially spark and modulated CW signals, when skillfully handled by experienced operators in a circuit particularly equipped for the proper voltage operation of filament and plate. The plate battery should be provided with taps and a potentiometer should be used across the filament in order to secure proper voltage adjustment.

It is not to be recommended for audio or radio frequency amplification and should never be used with a plate voltage greater than that obtainable from a single block "B" battery at full voltage.

This tube requires a little patience and skill in adjustment for the reception of weak signals. Under certain conditions it has a tendency to be slightly more noisy in operation than either of the high vacuum tubes which are practically free from such disturbances.

## Good for Loud Speaker

A powerful amplifier is the radiotron UV-201A and inherently a better one than the UV-199, and is particularly suitable for loud speaker operation.

It is designed to give the best possible amplification for general use, its amplification property not

being sacrificed to any extent to give a minimum of filament energy.

The operation of this tube is free from variations in results due to slight changes in plate and filament voltage. It is, accordingly, quiet in operation and it has a longer operating life than either the UV-199 or UV-200.

It is equipped with a standard base and thus fits in many sets already constructed.

The filament requires a much greater amount of electrical energy for its operation than does the UV-199, but the UV-201A tube can be operated from dry cells in the case of one or two tubes used only a few hours per day at a lower expense than with the use of a storage battery.

As an audio frequency amplifier, this tube is somewhat superior to the UV-199.

As an audio frequency amplifier, this tube is somewhat superior to the UV-199.

As a detector, the UV-201A is about the same in response as the UV-199 and is to be recommended over the UV-200 for most general purposes, except in equipment specifically designed for the latter tube as regards potentiometer adjustment for plate voltage and very fine adjustment for filament voltage.

It is very sensitive when used in the oscillating condition for reception of CW telegraph signals.

## Best for One Tube Set

The UV-201A radiotron is ideal for a one tube set and it is also ideal for a multi-tube set when a storage battery is available for filament operation.

When used for audio-frequency amplification, a negative grid bias, or "C" battery, should be used, the "C" battery voltage depending upon the plate voltage employed. The following table gives the correct value of "C" battery with different plate voltages:

Plate Voltages	"C" Battery Voltage
40	0.5 to 1.0
60	1.0 to 3.0
80	3.0 to 4.5
100	4.5 to 6.0
120	6.0 to 9.0

# Department of RADIO ENGINEERING

## Radio Topics Institute

NANKO C. BOS, Chairman Advisory Board



### Look for the Approval Seal

Such as the one just above which are furnished manufacturers whose radio merchandise has been tested and approved by the Institute Laboratory. We urge you to purchase only such apparatus, for it carries the guarantee of our organization.

Send all inquiries and material for test, calibration, or reconstruction to RADIO TOPICS INSTITUTE, Oak Park, Ill.

# Perfect Short Wave Receiver

By WILLIAM F. DIEHL  
Chief Engineer, A. H. Grebe & Co.

AT the present time numerous experimental stations are operating on a wavelength of 100 meters CW. Many stations are complying with the recent wavelength allotment where they may be heard on their wavelengths of 80 to 300 meters. Realizing this condition where such low wavelengths were to be received efficiently, a receiver has been developed and called the Grebe "13," which not only effectively covers the low wavelength range (80 to 300 meters), but also eliminates the interference which is bound to result when a number of stations operate on approximately the same wavelength.

The Cr "13" employs two vacuum tubes in its design, which embodies two important features in combination of circuits, namely, tuned radio frequency and regeneration. One vacuum tube acts as a radio frequency amplifier, while the other serves the purpose of a detector.

As the amateur rarely uses a loud speaker, no audio frequency amplification is needed.

In dealing with wavelengths between 80 and 300 meters it is important that the circuit constants be accurate and not subject to variation, as extremely high frequen-

cies are being dealt with, the average being between 3,700 kilocycles and 1,000 kilocycles. The accompanying photograph permits the reader to note how the units and circuits are arranged to prevent any such variations in the set.

In looking over the interior view of the "13" it will be seen that rigid bus-bar is employed in its wiring for connection between the various elements. Effective shielding is employed with all tuning elements, to completely destroy any body capacity effect that makes itself felt when the hand of an operator is placed on the dials or rheostats. To further insure fine tuning, which is so important on such low wavelengths, the dials are equipped with vernier wheels which allows the dials to be adjusted to a fraction of a degree.

#### Wiring of the "13"

Referring now to the wiring or schematic diagram of the "13," it consists of a primary circuit which employs a variable condenser, a split variometer and a stabilizer. In the plate circuit of the radio fre-

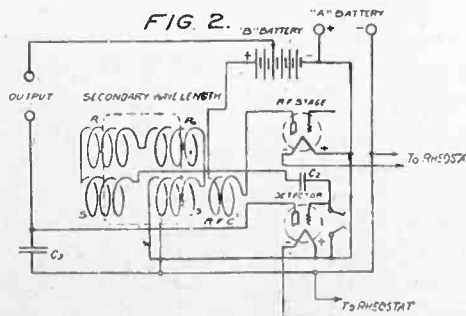
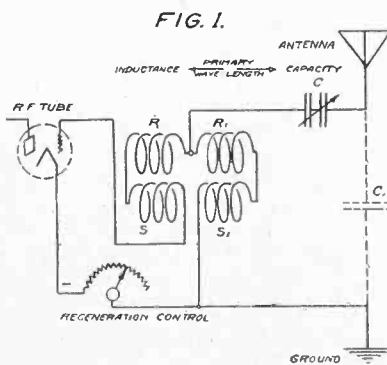

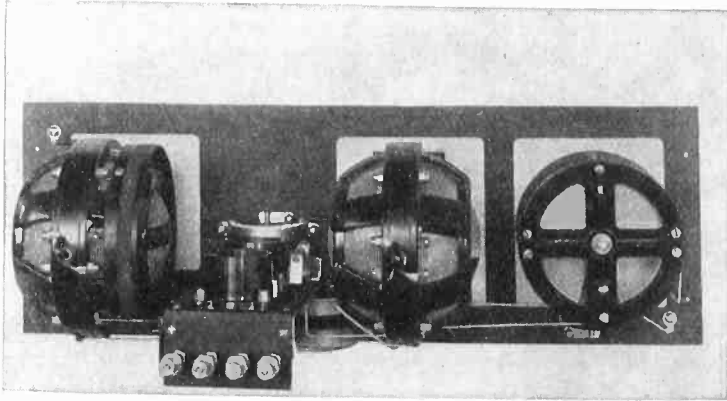

Rear view of panel of Grebe Receiver

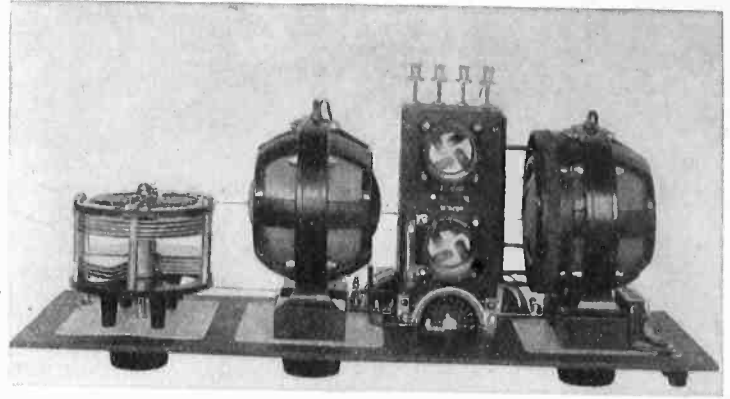

Top View of Grebe "13" for Amateurs

quency tube is a single layer coil which is inductively coupled to the grid circuit variometer of the detector tube. The usual grid condenser is employed with grid leak clips, so that grid leaks of various sizes may be used, depending solely upon the type of tube used. A bypass condenser, C1, is used to prevent the radio frequency currents from flowing through the telephones. The rheostats are of special design, and will allow current regulation on any make of vacuum tube, especially those pet tubes which have been broken in after a considerable length of time.

Referring to the internal wiring diagram, it will be seen that there are two principal tuning circuits. The primary circuit is designed as "primary wavelength," and has as variable elements a series antenna capacity and a special variometer type of inductance. The secondary circuit is designated as "secondary wavelength," and consists of a variometer similar to the primary variometer. Coupling between the two circuits is effective through the radio frequency plate coil designated as "R. F. C."

Figure 1 shows the primary wavelength circuit, which has as variable elements a series antenna capacity "C" and a special variometer type of inductance R, R<sup>1</sup>, S, S<sup>1</sup>. This variometer is wound to have a minimum wavelength of 80 meters and a maximum of 300 meters, and is connected across the grid and negative filament of the radio frequency tube through a variable resistance designated "Regeneration Control." Since there is no capacity in shunt to this variometer, the received signal will cause maximum voltage to be impressed across the grid and filament of the radio frequency tube. The variable

resistance employed controls regeneration according to the well known theory that a circuit will oscillate when the resistance is a certain percentage of the ratio of inductance to capacity.

#### Antenna Circuit Tuned

A careful study of Figure 1 will show that there is also an antenna circuit consisting of the effective capacity "C1" in series with the variable capacity "C" and the windings of the variometer R1, S1. The resulting with capacity (C1 in series with "C") across R1, S1 produces a circuit having a minimum wavelength of 80 meters and a maximum of 300. The antenna series capacity "C" is used to tune the antenna circuit, and has a range of capacity which makes it possible to use a regular transmitting or an indoor aerial.

The plate circuit of the radio frequency tube consists of a single layer inductance coil "R. F. C." in series with the "B" battery. This coil in shunt to the plate and filament of the radio frequency tube has a natural period below the working range of the receiver, and the coil is connected in such a manner that feedback takes place between the plate and grid of the radio frequency tube. This feedback action is due primarily to the coupling between the plate coil "R. F. C." and the primary inductance, but is increased by tube coupling and plate circuit inductance.

The wavelength of the secondary or detector grid circuit depends on the setting of the secondary variometer, which is of special construction and similar to the primary variometer. This variometer is connected across the grid and positive filament of the detector tube through the usual grid condenser. The inductance of this variometer is such that it produces a circuit having a minimum wavelength of 80 meters and a maxi-

mum of 300. As there is no shunt capacity across this variometer, the maximum voltage is impressed on the grid of the detector tube, resulting in maximum signal strength. The primary circuit is coupled to the secondary circuit through the plate coil "R. F. C." and this coupling is such that the wavelength of the secondary circuit is not affected by other circuit adjustments, which is important, since the secondary wavelength dial is calibrated directly in wavelengths.

Thus far we have not attempted to give any constructional data on the parts of this receiver, as the writer desired his readers to fully understand the function of each part before they attempted to construct the receiver.

As a detailed discussion has been made of the separate circuits, it now remains to describe the operation of the circuit as a whole, beginning with the antenna circuit and ending with the telephone or output circuit.

*(The second article will appear in February issue of Radio Topics.)*

### Specifications

- Primary Variometer, Split Type.
  - Rotor, 38 turns.
  - Stator, 38 turns.
- Secondary Variometer.
  - Rotor, 50 turns.
  - Stator, 50 turns.
- R. F. C. or Plate Coil.
  - 15 turns mounted on tube opposite stator connected to ground.
- Variable Condenser, .0002 max.
- Bypass Condenser, .001 mfd.
- Grid Condenser, .00025 mfd.
- Grid Leak, 3 to 5 megohms.
- Rheostats with 6 volt battery.
- Radio Frequency Tube, 30 ohm.
- Detector Stage, 6 ohm.
- Tubes.
  - Radio frequency stage 201A.
  - Detector stage, UV200.
- Potentiometer (regeneration control), 200 ohms resistance.



## CORRESPONDENCE WITH THE INSTITUTE

**T**HIS department is conducted by C. R. Bluzat, Technical Editor, RADIO TOPICS. Any inquiries addressed to him will be answered promptly, provided stamped and self-addressed envelope is enclosed with inquiry.

Please make your questions as concise or brief as possible.

This is your department. Use it freely.

TECHNICAL EDITOR, RADIO TOPICS,  
1114 North Boulevard, Oak Park, Ill.

### TECHNICAL EDITOR, RADIO TOPICS:

Am enclosing a sketch of a radio circuit which I wish to build if you think the circuit good. I wish to build a circuit which will receive WGY about 450 miles away during the day and work a loud speaker (Magnavox) during the evening.

I arranged this circuit with the tuned R. F. circuit in between the two transformers so as not to have too many controls and to use one potentiometer on the first two tubes.

I am bothered at present with telegraph at 600 meters and violet ray, also battery chargers and static. Will this circuit help to cut this interference out? And would you consider this an efficient all-around receiver for broadcast reception? And could you also recommend a radio frequency transformer for use with the WD12 tubes? Thanking you in advance.—H. E. M., Levis, Quebec.

In answer to your letter, I think your hook-up is satisfactory and would operate a loud speaker. However, the handling of the RF stages is more or less difficult for an amateur. You would obtain far better results in using a Neutrodyne as invented by Professor Hazeltine. This is very clear, very selective, and gives distortionless reception.

The November issue of RADIO TOPICS gives you full information about it and states details of construction. You will get exceptionally good results with this circuit. If you desire more volume you can add two stages of audio as you show on your hook-up. However, I would advise you first to try the three-tube circuit as described in RADIO TOPICS.

### RADIO TOPICS INSTITUTE:

In your issue of RADIO TOPICS for September, 1922, on pages 25 and 26, you explained a set which you had tested and in which I am interested. Can you inform me as to who manufactures it and their address?

Can you also inform me as to where I can get a list of books and the publishers of same on general radio topics—that is, not on wiring and such, but books of general information on this subject, and also where I can secure a dictionary on radio terms?—C. H. E., Webster Grove, Mo.

In answer to your query, the hook-up you refer to can be easily built by any radio shop in your home town.

Furnish them with the diagram from the September number and you will have an efficient set, easy to operate.

As for books on radio, ask a good book dealer and write to the Radio Corporation of America for dictionary.

### RADIO TOPICS:

As I am a subscriber to your magazine I take the liberty to submit the following questions concerning the peculiarities of the circuit, a pencil sketch of which is enclosed. I have been experimenting with this circuit for some time and find it gives very good signal strength and is selective but has some short comings that I am unable to figure out to date.

The inductance  $L$  and  $L^1$  are the primary and secondary of an ordinary 180 degree coupler (New York Coil Co.), the primary being tapped in tens and units, the tens switch ( $S$ ) and the units switch ( $S^1$ ) on the diagram. The secondary was rewound with 20 turns of 20 dsc wire in order that the tuner might tune down to 150 meters. With this winding I was unable to make the set oscillate, so changed to 40 turn of 20 dsc wire. With this winding in place the set will now oscillate from approximately 275 meters to 425 when switch ( $S^2$ ) is on the tap cutting out the secondary load coil, as per diagram. When the secondary load coil is in the circuit the set oscillates between 360 and 550 meters approximately. The set at the present refuses to go down to the 200 meter mark unless a bridging condenser of nearly .002 ( $C$ ) is used. I am using an RCA amplifying transformer ( $T$ ) and have never had trouble making other circuits function especially on the shorter wavelengths with this transformer in the plate circuit.

The variometer is a Kellogg, and I might ask if it is of too high an inductance value to tune the plate circuit to 200 meters in its minimum position. The condenser is an inherent balanced type tradenamed Ace and from all appearances its minimum capacity should not be too high for this circuit.

At one time I figured that the secondary load coil, which is 30 turns bank

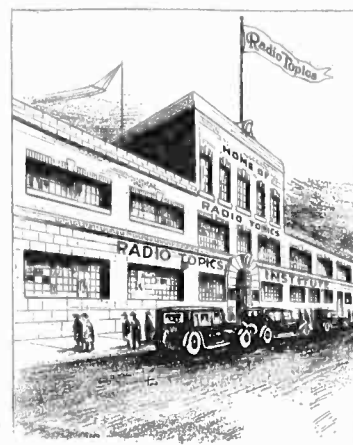

## Radio Topics Institute

Wishes All Radio Fans

### A Happy New Year

and extends a hearty invitation  
for 1924

To call on our radio engineers for help of  
any kind to adjust

Your Radio Troubles  
Free for the Asking

wound, might have an absorbing effect on the circuit, i. e., it might have a natural period of nearly 200 meters but it was removed and the results were the same.

Another thing which I cannot understand is the fact that when the load coil is in the circuit the tuning starts at minimum of the condenser and about 20 turns in the primary and the wavelengths increase as the inductance in the primary and the capacity in the secondary is increased up to a point where there is about 40 turns of the primary in use and the condenser plates are about two-thirds enmeshed then the wavelengths take a drop and 360 and 400 meter stations again begin to come in. This point of irregularity takes place around 550 or 600 meters.

The circuit is certainly a dandy and brings in both Atlantic and Pacific coasts on an aerial strung in the attic, but I would like to have it act more regularly so that I might know just where to look for a particular station. The Short Wave Kennedy Tuner and the Paragon R A 10 are very similar and I don't find them acting like this one does.

Any information that you could give me as to the erratic actions of the tuner will certainly be appreciated and I take opportunity of thanking you in advance for your help and the dandy magazine you are turning out at the present time.—F. F. S., Independence, Kans.

ANSWER: I have been very much interested by your letter. It seems to me that your plate circuit cannot be tuned low enough for 200 meter, this being due to your plate inductance and your

tube capacity filament to plate. When the 360 and 400 meter stations again come in, your set is probably tuned to an harmonic of these waves; in which case you should hear them with less volume than on the proper tuning. Apart from these little imperfections, your set is certainly working fine, since you say you hear Atlantic and Pacific stations on an inside aerial.

*I wish to refer to the article by Paul A. Perry. No doubt it was his intention to make his article clear and distinct and perhaps there are many who read it who can understand just how the coil is to be wound, but if they do they do it in spite of what has been said, in spite of the explanation and not because of it.*

*For instance, on page 16, November issue: "The plate coil consisting of 48 turns of 24 single silk covered wire . . . is wound into place. The tuning or antenna-ground and grid-filament inductances are WOUND RIGHT NEXT TO the plate coil and in the same direction, etc."*

*"Next to" doesn't mean much unless it is clearly stated whether it is continual winding or whether these windings are broken, separate and distinct and if they are, how far apart or, how much space should be left between the windings. Then*

*"These two inductances ARE WOUND AS ONE AND CONSIST of 55 turns, etc." The TWO windings consist of 55 turns? If this is true and the first or plate coil consists of 48 as mentioned above we have left but 7 turns for the other inductance coil or winding yet it follows on saying "On this inductance taps are taken off every 10 turns, etc." I can't figure it out and have handed it to about five radio fans to read and explain it to me but they can't. They say "I guess it means this or I guess it means that," but I don't want to guess. Won't you be good enough to explain this in a way a novice can understand?*

*Are the windings separate and distinct or is it continual winding? In either case, what space, if any, is left between the two windings? This is important.*—W. R. Van D., Philadelphia.

ANSWER: Answering your query, the article you refer to is in the October number and not in the November issue as stated in your letter. The tuning inductances are wound very close to the plate coil, no distance separating them, but they are distinct from the plate coil. The tuning inductances, antenna ground and grid filament form one coil of 55 turns on which taps must be made.

*Will you kindly tell me where I can buy the coils, condensers and radio frequency transformer, together with instructions for hooking up the Sun circuit described on page thirteen in your issue for November, 1923?—O. W. M., Kansas City, Mo.*

ANSWER: Answering your letter of November 23, write to the Sun Radio Co., 4884 North Clark street, Chicago. You will have to buy their tuner, which cannot be made but in a laboratory, due to balanced counter electric motive force which must be obtained.

## Milwaukee Amateurs

### Hear Lectures

CONTRASTED with last year the technical committee of the Milwaukee Radio Amateurs' Club, Inc., is no longer represented by one man investigating and reporting at meetings but is now the society's largest committee and perhaps its most active. Reports such as "The Relative Efficiencies of Battery-charger Rectifiers" by R. E. Lathrop, 9-ATX, former vice president of the Waukesha Radio Amateur Club; "An Amateur's Notion of the Heaviside Layer Theory" by M. H. Doll, 9ALR, West Allis A. R. R. L. city manager, and "The Remotely Controlled System at Station 9AAP" by M. F. Szukalski, Jr., are typical of this committee's work. Mr. Doll is chairman.

"Magnetism, and Some Original Experiments in Its Manifestation" was the title of an address given before the society by the Rev. John B. Kremer, S. J., A. M., professor of physics and director of station WHAD, Marquette University.

Father Kremer, known as an eminent physicist, has recently become a deep student of radio communication and has evolved a new microphone for broadcasting stations. Another lecture arranged by the program committee was "Tube Transmitter Design" given by LeRoy M. E. Clausing, 9AN, operating engineer at station WJAZ of the Chicago Radio Laboratory. As a program feature a contest in defining technical radio terms was held. Great enthusiasm was aroused, the winners being: C. R. Griesbacher, 9CYL, and M. H. Doll, 9ALR, who were awarded American Radio Relay League emblems.

On the same evening of the weekly meetings, Thursdays, only at 7:15 p. m., a code class for B. C. L.'s is held. This is in the Trustees' Room of the Milwaukee Public Museum and has been quite well attended, among those wishing to learn to receive the International Morse Code are two Y. L.'s.

Under the leadership of F. L. Catel, 9DTK, a most successful membership drive has been put over. From a large group of Milwaukee County non-member amateurs a majority has been induced to join the club and the American Radio Relay League, of which this society is a local section, M. F. Szukalski, Jr., 9AAP, the society's

vice president has recently been appointed A. R. R. L. city manager for Milwaukee and now heads the city's traffic work. An active campaign against spark stations has begun, and attempts to mitigate the spark interference to broadcasting, as caused by commercial transmitters on ship stations, are being made, for it is this interference that is most troublesome to local radio fans.

The traffic committee solicits reports of QRM for investigation. All communications to the club should be addressed to its general office, 601 Enterprise Bldg., Milwaukee, Wis., or its officers may be interviewed at the weekly meetings, which are open to the public.

## WLAG Selected by U. S. Bureau

Ray Sweet, chief engineer of WLAG, the Twin City (Minneapolis and St. Paul) Radio Central, operated by the Cutting & Washington Radio Corp., has been notified that WLAG has been selected by the U. S. Bureau of Standards as the bureau's "central" calibrating station.

WLAG was chosen as the result of a series of tests because of its power, central location and capability of being heard on both the Pacific and Atlantic coasts consistently. The government starts the calibrating work December 1, broadcasting signals all over the country so the 700 or more sending and hundreds of thousands of receiving stations may tune their wavelengths.

The eastern station designated by the bureau to calibrate is KDKA, the Westinghouse station at East Pittsburgh, which broadcasts to the Pacific coast with the aid of its relay station at Hastings, Neb. WLAG will pick up the Bureau of Standards signals in 300 to 600 wavelengths and as a single unit will broadcast them to all corners of the country. Stations tuning in will be able to regulate their wavelengths, reminiscent of the way watches were set by telephone from a central station on the battlefield during the war.

Government tests that led to the selection of WLAG, which broadcasts alternately from Minneapolis and St. Paul, shows that WLAG's wavelength, 417, varies the least—only a few cycles. The station operates with a 500-watt installation and motor generator set furnishing 1,600 volts. The entire plant is inspected daily and the wavelength is tested three times daily. WLAG has been heard at sea 450 miles west of Honolulu, in Europe, Cuba and Mexico.

# Mail Planes Radio-Equipped

**S**TEPS are under way, at the instigation of the postoffice department at Washington, to supply the government mail planes with voices and ears. The equipping of many of these planes with radio sending and receiving sets is expected to follow the completion of experiments which are now in progress, with every indication of success.

The advantages are obvious when it is realized that in time of heavy fog or severe snow storms, especially at night, a pilot might stray out of his course and find difficulty in locating his next landing station, even though aided by the powerful electric beacon lights which have been set up along the route. If the pilots and the landing stations can talk to each other, the pilot can be accurately directed from the ground, and thus always find his bearings.

There are also times when a plane has to make an unexpected landing, or when it is desirable to report to the landing field the presence of unusual atmospheric conditions. It has happened several times that air pilots have been forced to land at remote and isolated spots in the Rocky Mountains. When this occurs, with a radio outfit installed the pilot can immediately call for assistance instead of waiting hours and perhaps days for a searching party to find him. It is also an advantage to be able to transmit instructions to the pilot between stations, should occasion arise.

## Invaluable Adjunct

For all these purposes, as well as others, radio equipment on the mail planes will be invaluable, in the opinion of the department.

The feasibility of using radio sets, both transmitting and receiving, on the type of plane employed in the air mail service has been fully established by preliminary tests recently completed at Schenectady, N. Y. These tests, with a de Havilland mail plane, took place under the direction of radio engineers of the General Electric Company.

The radio equipment used in the tests was especially developed by the General Electric Com-

pany's radio department, in cooperation with C. F. Egge, general superintendent of air mail service, and Eugene Sibley, radio traffic supervisor. It is held to be, without question, a big step forward in the commercialization of airplane radio.

Powerful and highly efficient, the equipment is at the same time so simple that anyone can operate it successfully after brief instruction. In the Schenectady tests, the pilot was unfamiliar with radio apparatus, yet on every trial flight the operation was entirely successful.

## Easily Operated

Mail airplanes carry only one man, the pilot, in order to conserve space for the "paying load," i. e., the mail. This means that the pilot must operate the radio equipment in addition to his duties in flying. Consequently the equipment must be practically as easy to operate as an ordinary telephone. That this requirement has been fairly well met was demonstrated by the tests at Schenectady.

The pilot, in order to talk, merely throws the switch handle, conveniently mounted under his seat, to the transmit position and turns a large knob—the antenna Variometer—until the ammeter mounted on the board in front of him shows a maximum reading. That is the whole process of tuning the transmitter. After he has done that once, he locks the knob in position, and it is only necessary to throw the handle from "transmit" to "receive," as desired.

The receiver is of the "super-heterodyne" type, so selected because of its sensitivity and high selectivity, the latter reducing engine noises, and other interference to a minimum. While the seven-tube "super-heterodyne" receiver sounds complicated, in reality this one is very simple. Due to its special design, there are only two knobs necessary to adjust in tuning.

It is not possible to "duplex" on the plane, as with an ordinary wire telephone, although this may be done and in fact was done at the landing station. The pilot

must throw his switch back and forth to talk or listen, but that requires only a fraction of a second.

## XL Filament Tubes

The new famous XL or thoriated tungsten filament tubes are used throughout, and contribute largely to the successful operation and high efficiency of the apparatus.

The transmitter utilizes five 50-watt XL tubes similar to the UV 203-A, and the receiver utilizes seven UV 199 tubes, which operate entirely on dry cells.

The high voltage necessary for the plates of the 50-watt transmitting tubes is supplied by a 52-pound, 700-watt dynamotor, operating from a 12-volt battery and delivering direct current at 1,000 volts. The storage battery charges continually while the engine is running in exactly the same manner as the starting battery of an automobile.

The antenna for the mail plane radio equipment consists of a 200-foot trailing wire. This is carried on a special reel in the cockpit and let out when the plane takes to the air. A counterpoise, consisting of the engine, gas tank and all the struts and wires of the plane, connected together by bonding straps, is used for the ground connection.

During the time the installation work for the preliminary tests was in progress it rained constantly for two days and nights. As the equipment was only covered by canvas, it became thoroughly saturated with moisture, so much so that the aluminum brackets and other parts were covered with spots, where the drops of water had evaporated.

## Tests Successful

Yet the tests went off with great success. The apparatus was tested out on the ground without being dried, and operated perfectly, no tube or other failures occurring. During one of the trial flights both rain and snow were encountered at times, neither of which interfered with the operation of the set.

The tests comprised a number of trial flights from Schenectady. The ground station was the spe-



cial government call of WWS, assigned by the Department of Commerce. The longest flight made from Schenectady was when the pilot returned to Hazelhurst Field, Long Island, an air-line distance of about 175 miles, during which continuous conversation with him was carried on.

The final message was: "I am in sight of the landing field, and am going to reel in my antenna." This came in at Schenectady strong, indicating that the equipment could cover an even greater distance and that its normal rating of 100 watts output and 190 miles range, is undoubtedly conservative.

### Electric Show in Melbourne

Radio will be featured at exposition in Australian capital next September.

An electrical exhibition under the auspices of the Victoria Electrical Federation will be held in Melbourne during September, 1924, Assistant Trade Commissioner F. G. Pauly informs the Commerce Department. It is planned to cover every phase of the electrical industry, showing actual work models of the various types of apparatus from toys to machinery, transport, lighting and other industrial equipment. Both wireless telegraphy and telephony will have prominent places in the exhibition.

The duration of the affair will be for four weeks, taking in the period during which the Royal Agricultural Show is held, at which time Melbourne is crowded with thousands of visitors from the country districts. Further particulars may be secured by corresponding with the general manager, Edward Perugini, Victoria Electrical Federation, Melbourne.

### Exhibition in Barcelona

Inauguration of the Barcelona General and Electrical Exhibition (Exposicion Internacional de Industrias Electricas y General Espanola) has been fixed by a royal decree for October 12, 1926, Consul F. A. Henry reports. The exposition will close on July 1, 1927.

### Grebe CR-14 Receiver

**A.** H. Grebe & Co., Inc., for more than ten years engaged in the manufacture of radio receiving apparatus have recently introduced their type CR-14 Broadcast receiver to meet the rapidly increasing demand for a popularly priced instrument which operates at a minimum cost.

An instrument of rich, dignified beauty, the Grebe CR-14 adds charm to even the most elaborately furnished drawing room. All batteries are hidden in the attractively finished walnut cabinet. The circuit employed is the familiar Armstrong Regenerative Circuit. Two simple tuning adjustments used in conjunction with two-adjustment wavelength switch cover all broadcast wavelengths.

Three UV-199 or C-299 tubes are employed and special sockets to fit these tubes are provided. This makes it unnecessary for you to purchase adapters. These tubes require two dry cells for filament lighting current. These and the three B batteries all fit into two compartments in the cabinet. The B battery compartment accommodates the new vertical type.

The usual Grebe standards of connections are well carried out in the CR-14 Broadcast Receiver. The two Tapered Grip Dials are supplemented by the familiar Grebe Tangent Wheel Verniers. Individual shields, automatic filament control, rigid wiring and moulded parts of lustrous Bakelite are a few of the details of construction which have made the Grebe Receivers so popular.

This Receiver will bring in long distance as well as local stations with loud speaker volume using an outdoor antenna of moderate size. A 2-stage Audio Frequency Amplifier is included for loud

speaker operation. The operating switch, including the Grebe automatic filament control cuts in one or two stages of amplification at will.

The Grebe CR-14 Broadcast Receiver combines ease of operation, beauty of design and highest electrical efficiency. Those who are seeking a moderate priced instrument that can be operated at a minimum maintenance cost will do well to inspect this instrument at their dealer's.

### Radio Beneficial to Drug Addicts

Frederick A. Wallis, Commissioner of Correction, has inaugurated the innovation of installing a radio receiver and a Western Electric Public Address System on Riker's Island, thereby adding the inmates of the largest narcotic hospital in the world to the great and ever-growing audience that listens in to radio.

That modern miracle, because of its psychological effect, has a great value in the rehabilitation of the male drug addicts taking the "100 days' cure" on Riker's Island. Radio takes the prisoners' minds off themselves with beneficial effect.

By means of the Public Address System radio programs are made clearly and distinctly audible to all the inmates in each of the half dozen dormitories; and likewise, when connected with the microphone, the amplifying apparatus will enable the warden or other officials to speak simultaneously to all the prisoners without leaving his office.

When desired, any of the dormitories can be "isolated" by simply turning the switch in the warden's office that controls the sound projector in question.



A. H. Grebe's New Type CR-14 Broadcast Receiver

# Speeding Up the Morse Code

By S. R. WINTERS

**A** REVOLUTIONARY revision—and this term is used advisedly—of the method of transmitting the Morse alphabet with respect to radio telegraphy, land-line telegraphy, and submarine cabling, was outlined by Major General George O. Squier, Chief of the Signal Corps of the War Department, in a lecture before the National Academy of Sciences recently at a session in Washington, D. C.

The modified system of signalling would reduce the varying time period in sending the dots, dashes, and spaces common to telegraphy to a like duration. That is, in the transmission of the code, the dash, instead of requiring a period of time three times as great as that of a dot, the duration of each would be the same. Dots, dashes, and spaces would be distinguished by variations in the intensity of the signals.

The different intensities in a dot, dash, or space, under the proposed new system of signalling, would be effected by the use of alternating electric current and having each half cycle or multiple of half cycle represent one of the three individual sending elements, depending upon the intensity. These different intensities are, of course, accomplished at the transmitter.

This improved method of transmission has already been subjected to experimental application in submarine cables and a means provided for interpreting the alternating current into understandable signals. The variation in intensity was accomplished at the transmitter at the zero phase of the resultant electric current admitted into the cable, so that, in theory, at the moment of any operation upon the current there was no power to operate upon. Radically differing from the present system of the sending of the International Morse code, in the system being described no two adjacent signals are of the same sign since each semi-cycle is employed to obtain signalling, affording a dot, dash, or space.

The Code Section of the Signal Corps of the War Department, in applying this novel form of telegraphic alphabet to submarine cabling discovered that, other things being equal, the variations in intensities for each of the three elemental signals are reduced to the minimum on the theory that the minimum possible change of the fundamental wave should be made. The reason for this is that an alternating current in the

steady state, which amounts to a series of the present cable letters "a" or "n" strung together without space, can attain a speed in any form of telegraphy many times greater than any practical system, for the reason that a single line wave is transmitted through any form of electrical circuit without distortion of any kind, and, in fact, is the only type of wave that is so transmitted.

## Presents Striking Contrast

In striking contrast is this contemplated system of telegraphic

**"A**BOUT eighty years ago Morse invented the telegraph alphabet of dots and dashes, and the modification of it, known as the International Morse, is not the universal method of international radio telegraphy. This method is believed to be fundamentally unscientific, and the time has come to thoroughly consider a radical revision of the method of sending telegraphic messages." — Major Gen. George O. Squier, Signal Corps of War Department.

signalling to the method now in force. The powerful radio-telegraph stations, for instance, do not attempt to correlate the actual sending of the dots, dashes, and spaces with the phase or supply of electric current entering the transmitting antenna.

Consequently, in the sending of an ordinary communication a large power of three hundred amperes of electricity in the antenna may be abruptly changed in a

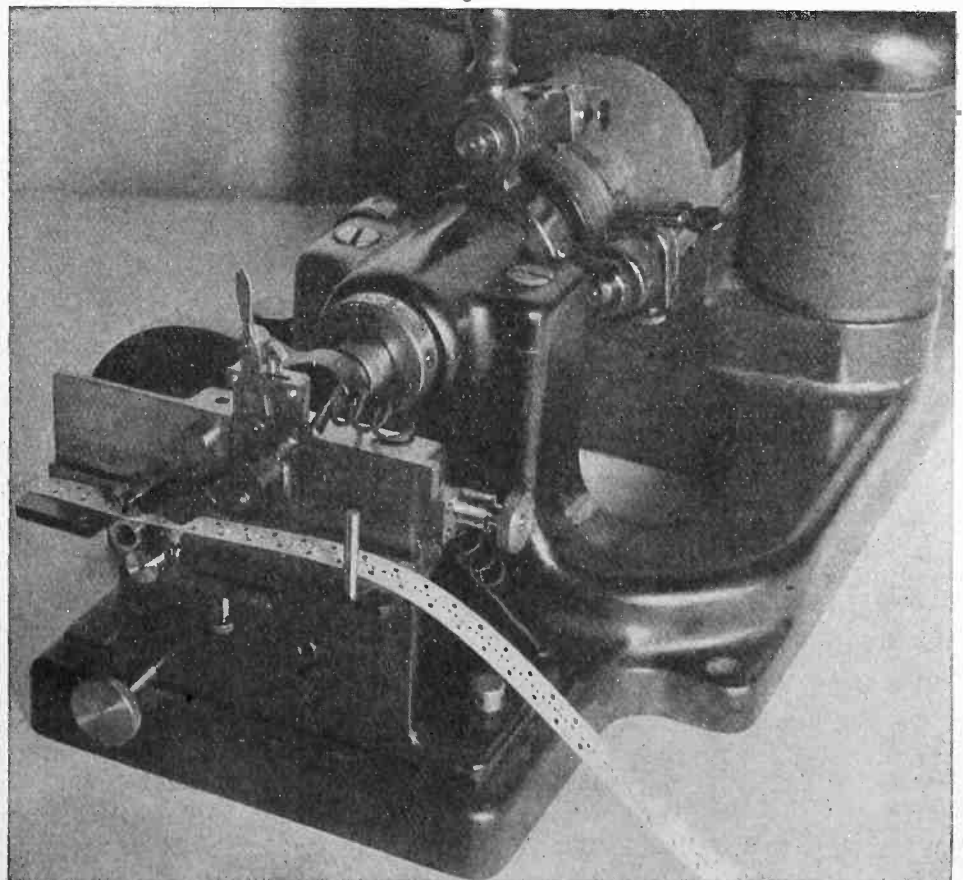

Transmitter for new alphabet applicable to radio, land lines and submarine cables.

haphazard manner. The telegraph key is opened or closed without regard for the phase of the antenna current. Thus, in the transmission of one message a relatively large supply of electric energy in the antenna may be interrupted at widely varying values—from zero to maximum, positive or negative.

Many of the existing disturbances in the ether, which mar the audible reception of radio-telephone messages, are blamed on the present method of radio-telegraph signalling. Radio engineers are cognizant of the fact that an abrupt breaking or introduction of high impedances in an electric circuit, using alternating current, produces transient phenomenon, ultimately resulting in the flood-harmonics. Coupled with this condition is the irregular procedure of operating powerful radio-telegraph stations on an antenna current varying from zero quantity to hundreds of amperes. Thereby, to employ a picturesque phrase of the Signal Corps, "the ether of space is bombarded with a mass of frequencies never twice alike in the same letter."

A gain of more than 150 per cent in the speed of the transmission of telegraphic signals is claimed in behalf of the sending of the Morse alphabet or code by the radical method outlined. In fact, the outstanding advantage of revision of the International Morse alphabet appears to be its accomplishment of facilitating a dispatch of a maximum volume of telegraphic traffic with the use of a minimum number of signals.

The existing Morse cable alphabet involves the sending of some of the letters by adjacent signals of the same sign, although the signals occupy equal periods of time. For instance, in letters such as "s" or "h," three or four signals have the same sign. The alphabet proposed by the Signal Corps indicates that no two consecutive signals shall duplicate the same sign; thus, for the first time a continuous wave of one definite frequency is used for the alphabet. Such an arrangement permits of the utilization of electrical and mechanical tuning, either or both.

#### Radio Frequency Channels Multiplied

A chart drawn by the Signal Corps illustrates the method of modulating a single frequency

wave, the principle involved in the proposal of dispensing with the time element in the sending of code and distinguishing the dots, dashes, and spaces by the varying intensity of the signals. The phrase "now is the time" is employed as a specimen of wording, by which method it is arbitrarily decreed that the largest amplitude represents a dash, the amplitude of ranking size assigned to a dot, and the third degree of amplitude is reserved for representation of the space necessary in the transmission of the telegraphic code. This method has been practically demonstrated by engineers in both the United States and England. The principle involved in this system of sending code ren-

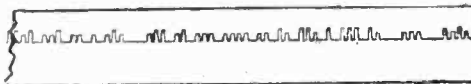
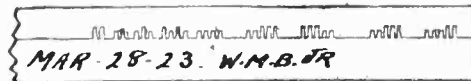

A specimen of transmission of the new telegraph alphabet.

ders it possible to modulate a single radio frequency by a number of modulating frequencies, and thereby multiply the capacity of each radio frequency channel.

This revolutionary theory with reference to a revision of the mode of transmitting the International Morse alphabet likewise contemplates a reduction of "static" or atmospheric disturbances, the constant bane of radio reception during the summer months. In this system of transmission very low modulating frequencies are employed, and according to the Signal Corps, it would seem relatively easy to devise instrumentalities enabling the vast radio audience to distinguish between low modulating frequencies and the higher frequencies of atmospheric and other natural disturbances. A chart prepared by the Signal Corps shows that a modulating frequency as low as ten cycles per second, which is considered a very high frequency for ocean cable practice, corresponds to 75 words a minute. This by far exceeds any form of sound reception. A modulating frequency of 60 cycles a second, the normal power frequency, corresponds to a speed of 450 words a minute, with five letters to the word.

If traffic dictates a reduction of this speed, according to this system of sending code, this may be accomplished by making the same perforations in the tape of the transmitting apparatus correspond to a suitable even multiple of a semi-cycle. To illustrate, by making each of the signalling units correspond to six complete cycles of current, instead of one semi-cycle, the rate of sending radio signals is curtailed to  $37\frac{1}{2}$  words a minute. This approximates the speed of commercial traffic. Thus, it is seen in this new method of sending the telegraphic alphabet, wave trains or frequencies are used as the elements for signalling.

#### Will Invade Infra-Audio Range

The radio engineers, according to existing practices, have utilized and adopted as his own all of the audio frequency range and at least several octaves of the radio frequency range. Moreover, engineering efforts have devised apparatus for the amplification and rectification of both audio and radio frequency ranges.

The plan outlined by the Chief Signal Officer of the United States Army at the meeting of the National Academy of Sciences contemplates an invasion of the hitherto unutilized infra-audio range. This, once achieved, would not only annex useful bands of frequencies, but would afford a band of frequency beyond the range of the human ear. An appropriation of this band of frequency for telegraphy would operate to the advantage of eliminating some of the interference now existing in the realm of the approximately 2,500,000 radio-telephone receiving sets in use.

Broaching the subject of the increasing confusion apparent in the ether, Major General George O. Squier said:

"Due to the rapid expansion of the use of radio telephony and telegraphy, the problem of interference, both natural and artificial, is becoming each day more and more pressing for solution. The conservation of the other lanes is suddenly rising to international importance. In addition, the daily growing uses of radio for the solution of auxiliary problems such as range finding, navigation, beacons, etc., further serve to complicate the problem, and

(Continued on page 34)





# New and Novel Radio Patents



## A NEW SPARK GAP

(Patent No. 1,473,070, issued to Samuel T. Woodhull of Medford and George J. Walker of Somerville, Mass., under date of November 6, 1923.)

The present invention relates to spark gaps for the production of electrical oscillations of relatively high frequency and more particularly to spark gaps of the quenched type.

The advantages of series spark gaps having a relatively short gap between each pair of plates for the production of powerful and highly damped electrical oscillations are sufficiently well known so that they need not be enumerated at this time.

One object of the present invention is to provide a spark gap of the quenched type which is simple in construction and efficient in its operation and is capable of being manu-

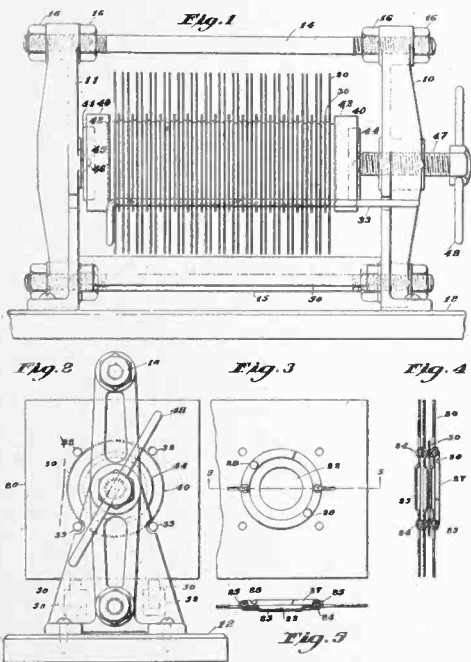

New Spark Gap

factured at a minimum cost. A further object of the invention is to provide a gap of this type which is capable of being readily assembled and disassembled in order to permit the necessary cleaning of the surfaces of the gap plates.

The accompanying drawings illustrate the preferred form of invention, Figure 1 represents a front elevation of the improved gap; Fig. 2 shows an end elevation of the gap illustrated in Fig. 1; Fig. 3 is a detail illustrating a view of the back of one of the gap plates with the spacing ring attached; Fig. 4 is a detail showing a section of several of the gap plates assembled; and Fig. 5 is a transverse section upon the line 5-5 of Fig. 3, showing the manner in which the spacing ring is attached to the gap plate.

The spark gap shown in the illustrated embodiment of the invention is of the multiple type having a series of gap plates provided with sparking surfaces so arranged with respect to one another that a relatively short gap is secured between each pair of opposed surfaces. Provision is made for enclosing each pair of sparking surfaces in a substantially air-tight chamber which is conducive to a long life of the gap plates, minimizing the corrosion and pitting of the plates due to repeated action. The apparatus as a whole is capable of being easily assembled or disassembled by an unskilled person.

The gap as a whole is supported between two upright standards 10 and 11 which are fastened to a base 12. These standards are rigidly connected together by tie rods 14 and 15 threaded at their opposite ends and connected to the standards through locking nuts 16. The gap plates are indicated at 20 and are of such a construction that they may be manufactured at a minimum cost yet when assembled in a complete gap provide an ideal form of gap chamber.

The several gap plates are identical in construction and each comprises a relatively thin sheet of electrolytic copper or similar material which is susceptible of being stamped or pressed into the desired form.

As shown in Figs. 4 and 5 of the drawings each plate 20 has molded in the central portion a depressed portion 22 substantially circular in shape and having a plane face 23.

This circular depression is surrounded by an annular trough (24) pressed out of the copper plate which is of less depth than the depth of the depression for a purpose to be presently described. A pair of ears (25) are struck up from the plate outside the trough 24 and serve to connect a spacing ring 27 to the back of the plate. This ring is so shaped in cross section that it lies in the annular trough 24 and is provided with transverse recesses 28 some of which receive the ears 25 when bent over into a retaining position. As will be observed from Fig. 3 of the drawings, the spacing ring is split which enables it to be seated properly in the groove when the several plates are clamped together.

## ROLLED CONDENSER

(Patent No. 1,470,781, issued to Phillip Thomas, Edgewood Park, Pa., under date of October 16, 1923.)

This invention relates to improvements in condensers and it has special relation to the lead connections of rolled condensers.

It is customary, in the manufacture of rolled condensers, in which there are several leads for each polarity, to solder the leads of the same polarity together. When this is done, after impregnation of the condenser with wax, the process of soldering several leads together requires so much time and heat that the condenser-impregnating wax is melted and air is allowed to enter the condenser at the leads. If, however, the leads are soldered together before the condenser is impregnated, the condenser is held rigidly in shape by the leads and is thus prevented from being properly impregnated. When the condenser is pressed, the leads are, moreover, pushed out of shape, if not broken.

My invention has for an object to provide a method of so connecting such leads as to secure proper electrical and mechanical con-

nection between the leads connected to each pole of the condenser, without injury, either to the impregnating wax or to the leads themselves.

In the drawing Fig. 1 is a plan view of a condenser constructed according to my invention; and Fig. 2 is a side elevation of the structure of Fig. 1.

The condenser 1 is shown as having terminals 2 and 3, each consisting of several leads 4. According to my invention, the leads 4 are inserted during rolling of the condenser, in the ordinary manner, and are allowed to protrude from the condenser. The condenser is then impregnated and the leads are cleaned and worked over to one side of the condenser, as shown in Fig. 1. The leads are then spot-welded together, is indicated at 5, and, subsequently, are preferably cut off just above the weld, after which any desired method of attaching lead wires may be employed.

This method of construction insures perfect electrical and mechanical connection of the leads. The spot-welding is accomplished in a very short time without injury to the impregnating wax and leaves the condenser properly sealed against air and moisture.

Where a condenser is to be used in locations in which it may be subjected to high temperatures it is important that every electrical connection be such that it will not be readily affected by heat. The leads connected according to invention fully satisfy this requirement.

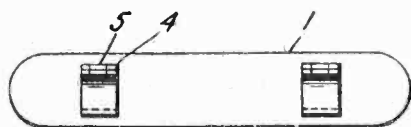

Fig. 1

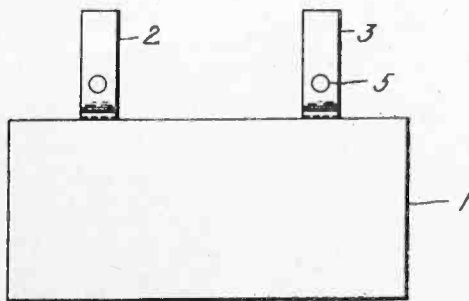
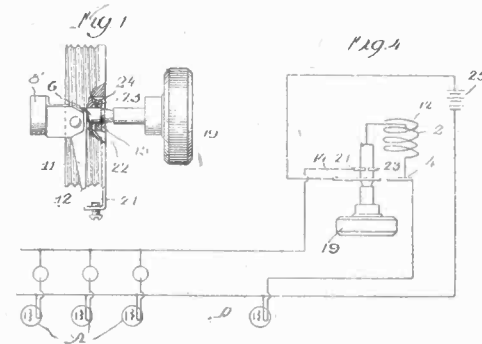
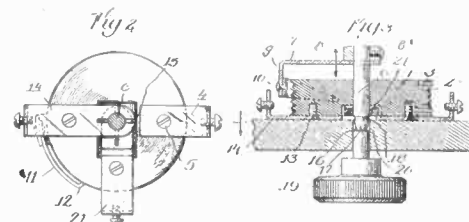

Fig. 2

Rolled Condenser



Combined Rheostat and Cut-out

## COMBINED RHEOSTAT AND CUT-OUT

(Patent No. 1,474,367, issued to John Elliott Jenkins, of Chicago, Ill., under date of Nov. 20, 1923.)

This invention relates to a combined rheostat and cut-out, particularly useful in radio telephony. Certain features disclosed in this application were disclosed in my co-pending application, Serial No. 543,859, filed March 15, 1922.

It is the object of the invention to provide a construction of the character described, simple and economical to construct and efficient in use.

Figure 1 is an elevation of the device partly in section.

Figure 2 is a plan view of the device.

Figure 3 is a cross sectional elevation, and Figure 4 is a diagrammatic showing of the elements of the device as applied to radio telephony.

I provide a drum 1, upon which in helical grooves cut therein is a resistance wire 2 secured at one end to the pin 3 and at the other to a terminal 4 secured to the flat face of the drum 1 as by the screw 5. Rotatably

mounted in the drum 1 and concentrically therewith is a spindle 6 provided with an arm 7 secured to the collar 8 which in turn is secured to the spindle by the screw 8'. The arm 7 is bent over as shown at 9 and pivotally connected as by rivet 10 with a contact finger 11 having a pointed end 12 which rides on the wire 2. By turning the spindle the end 12 may be made to travel along the wire, the pivotal connection 10 permitting the contact finger to follow the helical grooves.

Rigidly mounted on the face of the drum as by the screw 13 is the terminal 14. This terminal is in the form of a flat plate of conductive material, split at its ends as shown at 15 (Figure 2) and provided with an aperture through which the spindle 6 passes. The spindle 6 has a reduced portion 16 connected by the incline 17 with a smaller annular recess 18. The spindle 6 carries knob 19. The whole apparatus may be secured to a panel 20 shown in Figure 3, which panel may comprise the front of a radio control box.

It is obvious that turning the knob 19 varying resistance may be introduced with great precision, since the contact finger 11 travels along the resistance wire 2; and that by pushing the spindle in or out, contact may be made or broken between the terminal 14 and the spindle 6 in accordance as the small annular recess 18 or the reduced portion 16 of the spindle lies between the forked end of the terminal 15, since at the small annular recess 18 the spindle will be in contact with the forked end of the terminal, while the reduced portion 16 of the spindle will not contact therewith.

In order to increase the efficiency of the device and enlarge its usefulness I have, in this embodiment of the invention, added another terminal 21, which is fixed to the flat face of the drum 1 and which at its inner end passes down on incline 22 and is apertured at its inner end 23 to receive the spindle 6 with a snug sliding fit as shown in Figure 1.

In Figure 4 is disclosed a diagrammatic showing of the application of the device of the invention to radio telephony. In this figure is shown a battery 25 which is connected to the terminal 14 on one side and on the other side connected to the terminal 4, which through the wire 2 connects the battery to the spindle 6; thus an in-and-out movement of the spindle 6, by making contact between the terminal 14 and spindle 6, will complete the circuit through the rheostat and the detector D. The battery 25 is also connected through one or more amplifiers A to the terminal 21 and thereby through these amplifiers to the spindle 6; so that an in-and-out movement of the spindle 6 will establish or break the circuit, not only through the rheostat, but also through the amplifiers.

#### PROTECTIVE DEVICE FOR RADIO RECEIVING SYSTEMS

(Patent No. 1,475,632, issued to Harold B. Herty, New Orleans, La., under date of November 27, 1923.)

This invention relates generally to a radio receiving system and more particularly to a device for the protection of the receiving apparatus used therein.

In simultaneous transmission and reception of radio signals making use of separate but adjacent antenna, the energy radiated from the transmitting antenna is oft-times re-

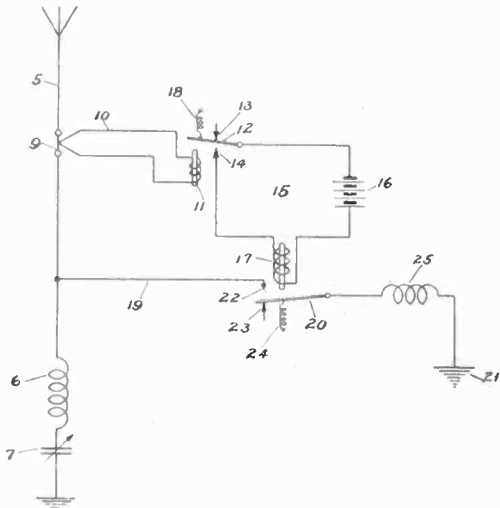

Protective device for radio receiving systems

ceived to such an extent by the receiving antenna that great damage is caused to the delicate receiving apparatus or, should this not happen, injury to the ears of the operator may occur.

To prevent any harmful results from currents thus received, I place in the receiving circuit an apparatus designed to automatically connect the antenna to ground when excess current flows in the antenna due to excess energy being absorbed thereby.

A receiving antenna is designated by 5, having the usual inductance 6 coupling the antenna to a receiver, variable condenser 7, and ground 8. A thermal device 9, which when heated produces current in circuit 10, is inserted in the antenna. The current thus produced energizes a solenoid inserted in the circuit 10. At armature 12 controlled by the solenoid 11 operates between a stop 13 and contact 14 to open and close a grounding relay circuit 15 which contains a source of energy 16 and solenoid 17. When normal current is passing through the receiving circuit, the armature 12 is held away from the contact 14 by a spring 18.

Circuit 19 in which is an armature 20 controlled by the solenoid 17 and adapted to open and close said circuit, connects the receiving circuit with a ground 21. The armature 20 is movable between a contact 22 and a stop 23, and is normally held against the latter by a spring 24. In order to prevent chattering in the members 22 and 23, I insert an inductance 25 in the circuit 19.

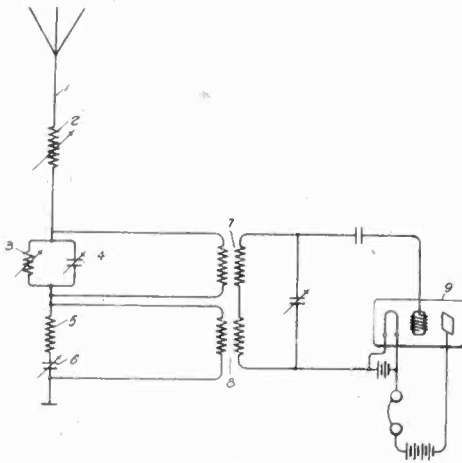

Radio Receiving System

#### RADIO RECEIVING SYSTEM

(Patent No. 1,477,413, issued to E. F. Alexander, Schenectady, N. Y., under date of Dec. 11, 1923.)

This invention relates to radio receiving systems, and more particularly to means for preventing interference in such systems with the reception of desired signals.

The object of this invention is to provide in a radio receiving system a means for preventing interference with the reception of desired signals from a near-by transmitting station having a different wave length.

In carrying the invention into effect I provide in connection with a receiving antenna means for impressing upon the receiving circuit two equal and opposing potentials produced in the antenna by the interfering wave. This means is so arranged that it will also impress upon the receiving circuit two potentials produced by the desired signaling waves, but these two potentials will be of different magnitude and of the same phase or will have such phase relation to each other that they will add in the receiving circuit and will not neutralize one another.

As indicated in the drawing, I provide in connection with the receiving antenna 1 in addition to the ordinary antenna tuning coil 2, two special tuned circuits, one being a multiple tuned circuit made up of inductance 3 and capacity 4 and the other being a series tuned circuit made up of inductance 5 and capacity 6. These two circuits are adjusted so that they are both in resonance for the signal which it is desired to suppress. The inductances and capacities of these two circuits are selected so that the multiple tuned resistance of the first circuit is substantially equal to the series tuned resistance of the second circuit. Each of the circuits has the character of a non-inductive resistance at the frequency to which they are tuned, hence the voltage drops between the terminals of each of these two circuits are equal and in phase. The voltage drop across the first tuned circuit is impressed by means of the coupling transformer 7 upon a receiving circuit and the voltage drop across the second tuned circuit is also impressed by means of the coupling transformer 8 upon the receiving circuit which is associated with a detector 9 of the audion type. The couplings 7 and 8 are so arranged that the potentials of a frequency equal to

that of the waves to be suppressed oppose each other in the receiving circuit and their effect is thus neutralized. Thus no signal will be received or detected of the frequency for which the two circuits are tuned. If, however, the frequency of the signal to be received is only slightly greater than the frequency for which these two circuits are tuned the multiple tuned circuit assumes the character of a capacity and the series tuned circuit assumes the character of an inductance.

## Another Midnight Revue

Wilson J. Wetherbee, director of station KYW, Chicago, announces that the Westinghouse station will hereafter broadcast another midnight revue on Tuesday of each week, as well as the regular Friday night program. The Tuesday program will begin at 10 p. m. and run through to midnight.

Many new features will be introduced to KYW followers as well as some of the musical numbers that are very popular at present. Chiefly among these will be the famous McVickers' Symphony Orchestra, under the direction of H. Leopold Spitalny, and the organ "surprise" which jumped into popularity through the novelty of its introduction and rendition and the superb playing of Mr. W. Remington Welch, organist at McVicker's theatre, Chicago. In addition to these features, the artists who are appearing at McVicker's theatre will be heard over radio. All this will be broadcasted directly from McVicker's theatre, Chicago, by means of a special sealed wire connecting the theatre with Westinghouse station. Between these numbers a special program of musical numbers will be sent out direct from the studio.



H. Leopold Spitalny, musical director of McVicker's Theatre, Chicago, directing his symphony orchestra while he listens to his own music, which is on the air every Friday night.

# Dry Batteries for "C" Circuit

By *W. B. SCHULTE*

*Secretary-Engineer, Burgess Battery Company*

**T**HERE is considerable interest being taken in the use of "C" batteries in new circuits. It is well known that under certain conditions a grid bias voltage of from 1.5 to 6.0 volts produces clear and distortionless signals and flash-light batteries have usually been used to obtain this required voltage. Perfect reception depends on a number of conditions, for example, the type of tube the plate voltage and the general characteristics of the receiving set itself.

In the early days of vacuum tube use, grid bias or "C" batteries were generally used in the circuit, but for the past few years and especially since radio has become a common sport, the tubes were operated without "C" batteries. There is a swinging back now to "C" batteries, as the value of the grid bias voltage is more appreciated and long distance reception is demanded by the broadcast listeners.

\* \* \*

As to the function of the "C" battery and its effect on the grid potential and plate current, the reader referred to the many articles on this subject. It may be stated, however, that it has been found satisfactory to connect the grid bias battery between the "A" battery terminal and the input transformer rather than between the input transformer and the grid. It is said that in the recommended connection there is not the possibility of the circuit picking up stray currents from other wires and causing noise from regeneration.

With reference to the "C" batteries themselves, they need not be of high capacity as the maximum current drain is probably under 5 milli-amperes. They should have a long self life or the ability to maintain a uniform voltage even when not in use. What the radio listener, then, is looking for is a battery for his "C" circuit which is long-lived, has a uniform voltage and is inexpensive.

Flashlight batteries consisting of two or three or more cells have been frequently used as a "C" battery. As far as size is concerned,

the medium sized vest-pocket flashlight or the tubular flashlight batteries have ample electrical capacity, but experience has shown that flashlight batteries as usually manufactured are not totally satisfactory as "C" batteries. One reason for this is that the cells in a flashlight battery are not as well insulated from each other as they should be for radio circuits.

\* \* \*

All dry batteries on slow discharge exhale a small amount of moisture and this moisture, if it is retained inside of the battery case will cause slow short-circuits. In a flashlight case these slow short-circuits are of small consequence as there is always an opportunity for the moisture to evaporate or the cell discharge is at such a slow rate that the battery is discharged from use rather than from the short-circuit. In a "C" battery, a slow discharge of any of the cells would cause a voltage fluctuation impressed on the grid circuit and results in a distortion of signals. To prevent these slow short-circuits in "C" batteries, heavier insulation should be used in flashlight batteries and a number of manufacturers now make "C" batteries with such cell insulation.

These batteries are usually in water-proofed outer cartons to prevent the entrance of moisture into the cells. The insulation between cells is heavy, paraffined separators and in some cases the cells themselves are each contained in another water-proof envelope. This construction prevents the entrance of moisture from the outside and confines the inner moisture to the cell compartment and prevents it reaching out into contact with other cells and discharging the battery.

\* \* \*

If the radio listener cannot obtain standard "C" batteries and it is necessary for him to use flashlight batteries, he should arrange them so that positive contact is always made between cells. In the tubular flashlight batteries, for example, there is only a point contact between the positive carbon of one cell and the negative zinc can of

the other. The user must see that the contacts are clean and that there is enough pressure on the top and the bottom of the battery to have good electrical conjunction between the cells. In the flat vest-pocket type of battery the user cannot interfere with the cell connections and his only precaution is to be sure that the contacts with the battery brass springs are perfect.

If flashlight batteries on the "C" circuit become moist or increase in size from expansion or the inside, the battery should be immediately discarded and replaced as they will have passed their usefulness.

\* \* \*

Inasmuch as the battery manufacturers who have been studying radio batteries for many years are now marketing special radio batteries for "C" circuits and as these batteries can be obtained at practically the cost of the flashlight battery, the radio user will be avoiding trouble and saving money by purchasing regular "C" batteries for his set. The experience of years of laboratory testing and actual service has demonstrated that these specially constructed "C" batteries are more satisfactory than flashlight batteries for this particular purpose.

## Contest Ends

The radio drama prize competition, inaugurated by WGY, the General Electric Company station at Schenectady, N. Y., was extended one month and closed December 31 instead of November 30, as originally announced.

Many manuscripts were received. The object of the competition is to develop a type of play that is especially adapted to radio presentation, a type of play that tells its whole story through an appeal to the ear and the imagination, just as the screen play is directed exclusively to the eye.

A prize of \$500 was offered for the best original drama submitted under the terms of the competition. Additional prizes in varying sums up to \$100, depending on merit, will be awarded at the option of the General Electric Company for other plays deemed suitable for radio production.



# Hints on Adjustment of Radio Receivers

By L. W. CHUBB

*Manager of Radio Engineering Department, Westinghouse Electric & Manufacturing Company*

**R**ADIO broadcasting! What is it? It is a great public service from which some get instruction, others entertainment—that a great percentage of listeners consider a great indoor sport. We may say that radio broadcasting is all three and as such should be governed by rules and etiquette which will enable everyone to get the most enjoyment from it. We hear many people speak of the invisible audience, but how many visualize this audience and appreciate that others in the audience or that they, in any way, affect the reception of others.

The fisherman or the golfer obtains equipment best suited to his individual needs, and learns to use it effectively by instruction or experience. He may or may not interfere with the pleasure of other sportsmen. He is expected to follow a code of etiquette.

In the theater large hats are removed in consideration of those behind; at the ball game a "down in front" is forthcoming if one interferes with the vision; and in the town meeting we do not put up with the noisy individual in the audience who interferes with his neighbors by radiating his opinions. After a slight consideration of each one's part as a member of the radio audience it will be appreciated that corresponding conditions exist and that radio receiving must be played as a gentleman's game.

## A Receiving Station

A radio receiving station consists of some form of antenna connected to a radio receiver of one of several types. The antenna intercepts the wireless waves and absorbs an amount of energy dependent upon the size of the tuned antenna and the conditions of operation of the radio receiver. The waves induce currents in the antenna circuit which re-radiate energy from the antenna. Each station then takes from the passing waves an amount of energy equal to the difference between the energy intercepted and that re-

radiated. It is evident therefore, that each station may cast a sort of wireless shadow and thus reduce the strength of signal left for those in the back seats of the vast audience.

Our great auditorium, unfortunately, has the cheap seats in front. Around each broadcasting station are thousands of listeners using crystal receivers which require the most energy, re-radiate the least, require the largest antenna, and therefore, cast the greatest shadows beyond.

An important hint therefore, in the operation of a crystal receiver is to de-tune the instrument when it is not in use. This does not mean that the adjustment of the crystal need be disturbed—merely move the tuning adjustment to one extreme or the other. An antenna out of tune casts no shadow.

In addition to the crystal receivers in our radio audience, there are thousands of vacuum tube receivers used at various distances from the transmitting station. These fall into three general classes: the simple tube set with-

out regeneration; the regenerative receivers; and the receiver with radio frequency amplification, usually working with a loop antenna.

## Tube Set Effective

The first, or simple tube set, owing to its lack of sensitivity, can be used effectively only within a short distance of the broadcasting station. This type of set is usually simple to operate, requiring only the adjustment of tuning after the filaments of the tubes have been lighted.

The regenerative receiver is the most common set in use and, on account of its high sensitivity and selectivity, when properly used will be found to be the best all around radio receiver. It is this type of receiver that I particularly wish to refer to. Many operators attempt to use such an instrument with the same large antenna that was used with a crystal set, and thereby lose the advantages of the receiver. They wonder why the receiver picks up several signals and apparently will not select one alone. The trouble is with the antenna. The sharp selective tuning of a regenerative receiver can be taken advantage of only with a small antenna. It is not necessary to use a double circuit receiver to obtain satisfactory results and prevent interference.

Theoretically, with a small antenna the same strength of signal can be obtained at the best point of adjustment of tuning and regeneration. Practically, the adjustments can be made so close that no appreciable signal is lost and the sharpest of tuning is obtained. If one is troubled by the reception of two or more nearby stations at the same time, a small indoor antenna should be used across the top of the room or of the room above. This will allow the separate selection of signals, unless they are on almost the same wave length, and, with little practice in adjusting the instrument, distant signals can be picked up readily and satisfactorily. To obtain the best result with the

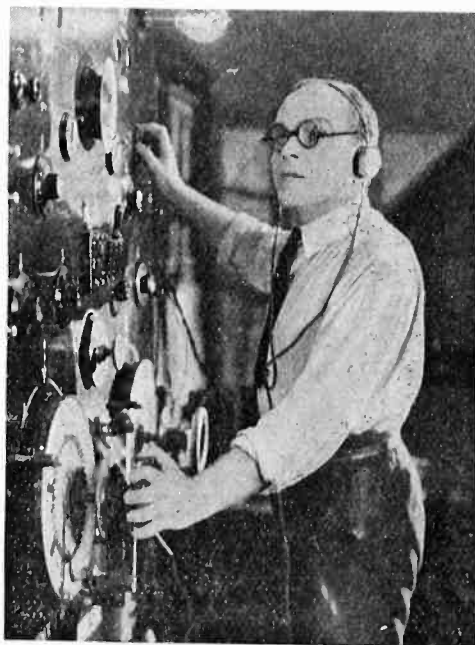

LISTENING TO MARS

A scene from "Radio Mania," a new film just made by Herman Holland and which W. W. Hodkinson is distributing. Grant Mitchell is the star of the photoplay, and the plot concerns a young man's efforts to talk to Mars.

regenerative receiver the operator should use only the preferred methods of adjustment, and I wish to call attention to some of the important things to be considered in the operation of this type of receiver.

#### A Regenerative Receiver

Most of the users of the regenerative receiver know that it has an Armstrong circuit, and that by the adjustment of a "tickler," "intensity regulator," "plate variometer" or "regenerator," whichever it may be called, the signal can be increased greatly. They know also that at a certain point the detector will commence to oscillate and the receiver will omit whistling noises or beat notes, as they are called, when the tuning is run through an incoming wave. Few of those using this type of receiver, however, know that these whistling noises can be heard in a neighbor's receiver and that similar noises which are heard when a set is not being adjusted are caused by a nearby receiver improperly adjusted.

As regeneration is increased the amount of re-radiation from an antenna increases until, at the point just below oscillation, the re-radiation is equal to the absorption, the loudest clear signal is received, and the receiver neither disturbs a neighbor nor absorbs any appreciable energy, which can pass on to the more distant listeners.

The most common infractions of radio etiquette are the use of regenerative receivers while oscillating and the hunting of signals by picking up the carrier wave with the detector tube oscillating. Most radio operators have found that by

careful adjustment the "beat note" can be lowered in pitch to a central point where the noises stop and a signal can be heard with the tube oscillating. This adjustment is known as the method of "zero beat reception." Under this condition, a receiver radiates more energy that it absorbs so that the station can be considered as a booster station which will reinforce a passing radio signal. If such booster stations were properly located and the adjustments could be made so as not to produce any distortion, this method of receiving might help reception conditions. This however, is not the case and zero beat reception should be avoided. It will be found that the quality of signal is greatly impaired under this condition of adjustment. It is evident also that getting in and out of the "zero beat" adjustment will cause disagreeable noises in the neighborhood and even when the adjustment has been obtained many snorts and grunts are produced by the slightest change in the wave length of either the transmitting station or the receiver.

In hunting signals it is a common practice to have the detector tube oscillating and then, after finding a carrier wave, to lower the regeneration to a point below oscillation to clear up the signals. This practice disturbs others who may be tuned to the same wave and is an unsportsmanlike procedure that ruins their enjoyment of radio broadcasting.

#### Important Suggestions

I should like to suggest the following method of receiving broadcasting programs with regenerative

receivers. After adjusting the filament currents of the vacuum tubes to a point which has been found to be satisfactory, increase the regeneration to a point just below oscillation. Now tune the set slowly up or down the scale, keeping the regeneration adjusted just below oscillation until the desired signal is heard or a breathing sound is noticed, indicating the presence of a carrier wave from a station which may not be operating at the instant. If the receiver is well designed the adjustment for regeneration will be practically the same throughout the range of broadcasting wave lengths and any worthwhile signal can easily be tuned in, after which the volume can be increased by a final adjustment of the regeneration. You will soon be able to pick up signals just as easily by this method as you can by the beat note method. If everyone will hunt signals and listen to the music with the detector tube adjusted in this way, the quality of broadcast programs will be very much improved. The gurgling, rough, and distorted music which is now heard, in a large part is due to the re-radiation from many oscillating receivers, will disappear. The whistling noises which go up and down the scale, due to a neighbor's hunting signals with an oscillating receiver, will be eliminated. The steady screaming notes which are heard at or around the signal from a broadcasting station are due to interference between two or more broadcasting stations, and cannot be eliminated until a great number of these stations are closed up or are given individual and separated wave lengths.

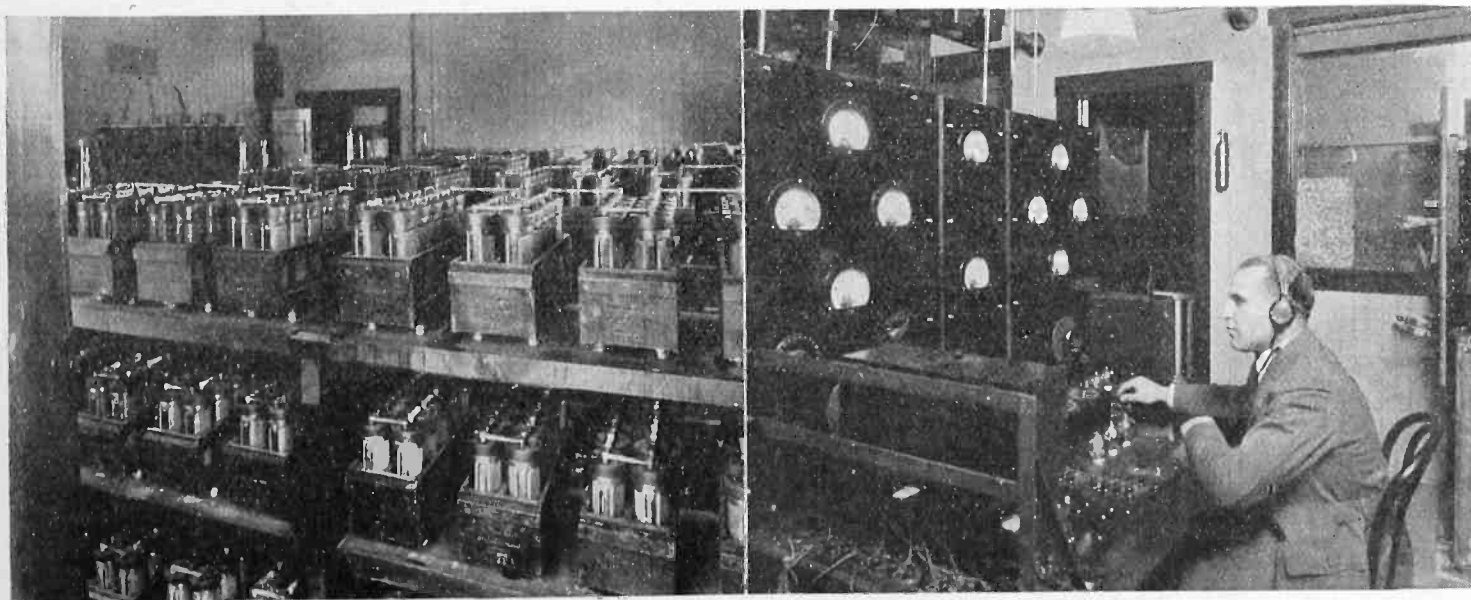

Two excellent views of station WTAM, the Willard Storage Battery Company's broadcasting plant at Cleveland. Left, the storage batteries which supply the power for the station. Right, S. E. Leonard, operator of WTAM, who designed and personally supervised the entire building and installing of the station.

## English Radio Fans Get WYG

**T**WENTY-ONE English radio fans have written WGY, the General Electric Company broadcasting station announcing successful reception of the Schenectady station's program during the first week in September. WGY and other American stations have been heard frequently by the English fans but trans-Atlantic transmission is rather unusual at this period of the year.

Many of the writers compare WGY with the transmitting stations in England and on the continent and a majority of them refer to programs broadcast September 6 and 8. W. E. Philpott of Rye Sussex, England, picked up WGY in the early morning of September 1. He writes, "I was rather 'bucked' up with the results. Congratulations on the fine modulation. You were quite equal to Birmingham and Manchester."

Henry Myers of Low Fell, Durham, England, heard WGY and writes, "For consistent strength and clarity the concert came through much better than I get the London transmission."

J. Rhodes writing from Leeds, Yorkshire, England, said WGY was as "clear as Manchester 40 miles away."

The report of H. L. Holt of Manchester, England, is especially interesting, inasmuch as he received WGY on an indoor aerial. He writes: "The apparatus I was using consists of an indoor aerial across the kiddies' bedroom and the ordinary detector and one stage of low frequency. The aerial is just a length of bell wire stretched backwards and forwards across the room in the form of a W and a V, and then through the floor to the living room below the set. The tuner is just an ordinary single circuit regenerative one."

Reception on a loud speaker strong enough to wake a person sleeping upstairs with bed room door shut, is reported by T. Hall Felton of Grimsby, England. Mr. Felton was listening in with his father, Dr. E. H. Felton, who is vice-president of the Grimsby District Radio Society. He has a five-valve (tube) experimental set. "On two high frequency valves," he writes, "you are as loud as the English stations on three valves. In operating the loud speaker five valves were used." Mr. Felton

**ACE  
RADIO  
SETS  
ARE  
FAMOUS  
FOR THEIR  
CLEAR  
RE-  
CEPTION**



**BUY  
AN  
ACE—  
ENJOY  
THE  
WORLD'S  
BEST  
ENTER-  
TAINMENT**

### Ace Type 3C Console

This is a comparatively new addition to the Ace Family. It has beautiful solid mahogany, wax finished cabinet and greatly adds to the appearance of any home.

This set consists of a regenerative tuner, detector and two stages of amplification, with built-in loud speaker. The tuning circuit is licensed under the Armstrong U. S. Patent No. 1,113,149 and due to the particular method of winding Crosley coils it is exceptionally selective. Has sufficient room inside cabinet for dry batteries, making a complete self-contained long range re-

ceiving outfit. Has phone jack for tuning with head phones. Crosley multi-stat; filament switch; Crosley moulded condenser, beautifully engraved Formica panel. Uses all kinds of tubes. Price \$125.00. Prices do not include batteries or tubes.

The Ace Type V is another member of the Ace Family—a one tube set selling at \$20.00 and the Ace 3B selling at \$50.00 is also very popular among radio fans. Both are licensed under Armstrong U. S. Patent No. 1,113,149.

If your dealer cannot supply you, order direct, mentioning his name.

**The Precision Equipment Co.**  
Powell Crosley, Jr., Pres.  
123 VANDALIA AVE. CINCINNATI, OHIO

picked up WGY on September 4, 6 and 8.

H. Constable of London heard speech and music on September 1. "At 5:23 a. m. I heard your station working and easily got your speech and music on a small loud speaker. I got you comfortably on one high frequency and one detector valve and with two note magnifiers worked the loud speaker." Mr. Constable sent in a log but failed to get the name of a hymn. In place of the name he wrote a portion of the melody in musical notation. This was recognized and it checked perfectly with the WGY station log.

It would appear from the letter of Gilbert Davis of Magheramorne, via Belfast, Ireland, that American broadcasting stations threaten to cause violation of law in Ireland. Mr. Davis writes: "I can get your music any evening but your speech only when X's are fairly quiet. Your transmission is far better than any in Paris or the Hague. Owing to my set having only three valves (one detector, one high frequency and one amplifier), most of my friends are very doubtful as to my getting you, and as 'curfew at 12' exists still over here and I cannot let my friends listen in for themselves."

In addition to the letters received from Great Britain WGY received letters from E. M. Bacigalupi of Hillyard, Washington; Charles Maginn, Jr., of Aberdeen, Wash., and Paul Berner of Shaunavon, Saskatchewan, mentioning reception of the program of September 8.

## St. Paul on Air

**S**T. PAUL made its debut as a permanent radio broadcasting station December 12, with the initial program from the new studio in the St. Paul Athletic Club.

Programs will be broadcast alternately with those from Minneapolis over WLAG, the Twin City Radio Central, operated by the Cutting & Washington Radio Corp., in Minneapolis, the St. Paul studio becoming a unit with WLAG. Heretofore irregular St. Paul numbers were broadcast from the Minneapolis studio or an emergency St. Paul studio.

Eleanor Poehler, the only woman in complete charge of a radio broadcasting station, who has been in executive control of WLAG the last year, will also have charge of the St. Paul studio. The St. Paul Athletic Club orchestra, better known as the "Call of the North" orchestra and other St. Paul artists featured the dedicatory program. Ethel Johnson, WLAG announcer, introduced the other studio personnel.

The new St. Paul studio will be conducted under WLAG's "community broadcasting plan" with St. Paul commercial and civic associations and business concerns subscribing to programs. These include the St. Paul Retailers' Association and the St. Paul Jobbers' Association.



# No Distortion from This Amplifier

**C**ONTINUING their work of improvement of radio station WBZ in Springfield, Westinghouse engineers are putting in the latest devices and apparatus developed for better broadcasting of all types. The most recent addition to the excellent equipment of this New England station is a voice amplifier of entirely new design which reproduces and magnifies the sound impulses without distortion before they are "fed" to the station's transmitter.

To understand the importance of a voice amplifier free from any distortion, it is necessary to have an idea of this problem, an important one in transmission of the human voice and of music by radio. Sometimes, when you are receiving a distant station and you decide to "plug in" another stage of amplification, the signals which you had been getting very clearly and loud will almost lose their identity and be distorted in the extreme. The receiving and amplifying circuits must be adjusted at once, so that the amplifier will operate properly. This problem, but many times bigger and more important, is presented at the transmitting station.

Station WBZ is a remotely controlled station. That is to say, the studio is at a distance from the broadcasting equipment. In this case, the studio is located in the Kimball Hotel, in Springfield, while the transmitter is located at the top of the Westinghouse plant in East Springfield, a distance of approximately 4 miles.

When the artist sings or speaks into the sensitive microphone at the broadcasting studio, very little energy is released, and the electrical impulses into which the soundwaves are converted are too feeble to make the journey to the plant four miles away and actuate the very delicate and sensitive apparatus of the transmitter. It is, therefore, necessary to reinforce these impulses before they start on their journey, so that they will be strong enough. This is done through the use of an amplifier. This amplifier is some-

what similar to the one used in a receiving set, but it makes use of larger vacuum tubes, and handles a larger amount of energy.

## A New Design

Just as with the receiving amplifier, however, if there is too great an amount of current flowing through it at a given time, there will be distortion, which will be at once transmitted out into the ether, and which will be received by a normal receiving set as a signal of very poor quality.

The design of these station amplifiers is a great problem because of the fact that they must be made to amplify over a band of frequencies equal to those obtainable with the average orchestra, from the highest to the lowest note, and still amplify normally every tone. At the same time, they must be able to handle the necessary amount of current to operate the transmitter.

Westinghouse engineers have been studying the problem of amplification for a long time. Finally, the push-pull system of amplification was evolved. Those of you who use Radiola Grand Receivers know what excellent quality of tone can be obtained with the amplifier of that instrument. It is a push-pull amplifier which makes use of two WD-11 vacuum tubes. There is no distortion, and yet the intensity is such that it is at times necessary to cut the volume down.

An amplifier, similar in design, but capable of handling many hundred times the energy which the receiving amplifier does, has been installed at station WBZ. Because of its construction, it requires duplicate equipment throughout. The vacuum tubes are employed where one was needed previously, two sets of batteries, transformers with double windings are other modifications which have been necessary. This duplicate layout, though necessarily more expensive in cost and operation, has several very important advantages. In the event of something

going wrong with the vacuum tubes, batteries, or any part of the amplifying system, the station is not for that reason put out of commission. The system operates continuously upon the duplicate set, which acts as an emergency system until the entire unit can be repaired quickly.

## Duplicate Circuit

Most important of all, however, is the fact that because of this duplicate circuit arrangement, more current can be handled, and therefore, no distortion will be experienced. Perfect reproduction at the transmitting end can be had. In fact, a second amplifier, identical with the first, is installed at the East Springfield plant, so that the electrical impulses from the studio are still more strengthened before going to the transmitting set. By properly regulating all of the circuits in the amplifier system, a current intensity of almost any magnitude can be obtained. This control is a valuable feature in case the broadcasting of a singer with a very powerful voice is attempted. It would be disadvantageous to the tone and quality of the singer's voice to have the latter sing lower. However, the end can be accomplished by regulating the current intensity in the amplifier circuit, without the necessity of moving the microphone away from the artist. This control is also necessary in the case of theater broadcasts, in which the artists move about the stage, and where the voice appears ordinarily to get stronger and weaker as the speaker approaches or walks away from the microphones located near the footlights and about the stage. The operator who listens in at the station can, by a slight twist of a knob, maintain the current practically constant, so that the broadcasts will be uniform in strength.

Most of the installation work was in charge of Frank Falkner, radio engineer of the Westinghouse Electric Company. Improved reception of the WBZ broadcasts has already been noted by many listeners.

## GAMBLING?

YOU ARE IF YOUR RADIO TUBES ARE UNPROTECTED

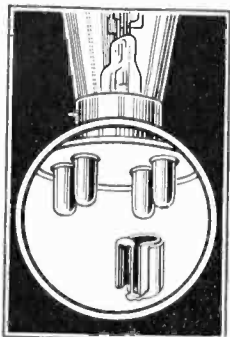

Your Vacuum Tubes are the most delicate parts of your Radio Set.

They are easily blown out—you have probably already had this exasperating experience—it is apt to happen at any time.

"B" Battery wires accidentally crossed for only an instant with the filament leads or sudden excess current from the "A" Battery will do it.

You can prevent this and save yourself money and inconvenience and relieve your mind at a trifling cost.

### INSTALL RADECO SAFETY FUSES

on all your tubes. Applied in an instant to one of the filament terminals. Will fit any standard tube going in any standard socket.

Price 50 cents each, sent postpaid and fully guaranteed. Do not delay. Order now. Specify type of tube used.

DEPT. 4

### Radio Equipment Company

Manufacturers and Distributors of Standard Radio Equipment

630 WASHINGTON STREET

BOSTON, MASS.

New England's Oldest Exclusive Radio House  
Dealers:—Write for our proposition

### SPEEDING UP MORSE CODE

(Continued from page 26)

furthermore, it is believed that we are on the threshold of another development, viz., photo-broadcasting, which will require and demand still additional ether channels to serve the public of the near future. It may be said, therefore, that the fundamental problem for the radio engineer is to devise methods to utilize these limited channels to the greatest extent possible, and to bend his efforts to the extension of their limits, both high and low.

"In the case of artificial disturbances the chief offender, from an engineering standpoint, is radio telegraph practice as it is universally conducted at present. Radio telephony and music of all classes have a form of modulation which is scientifically more sound than that of telegraphy. It is impossible at present to tune out the high power radio-telegraph stations, especially when a receiving station is in close proximity. Such stations, as at present operated,

produce a veritable eruption in the ether, creating disturbances over a wide range of frequencies, and these serve to interfere with any form of radio receiver yet devised. Who has not experienced this in the operation of his radio receiving set? Radio telegraphic transmission, therefore, demands new consideration and new study from a scientific standpoint.

"About eighty years ago Morse invented the telegraph alphabet of dots and dashes, and the modification of it, known as the International Morse, is now the universal method of international radio telegraphy. This method is believed to be fundamentally unscientific, and the time has come to thoroughly consider a radical revision of the method of sending telegraphic messages. I do not here refer to an actual change at present in the Morse alphabet as regards the combinations of dots, dashes and spaces assigned to each letter, but I refer to the study of the correct method of sending these combinations in

any circuit, whether radio, land lines, or submarine cables. The problem is the same in each of these three branches, but it is much more serious in radio for the reason of the necessary broadcasting properties thereof.

"The rapid increase in the use of printing telegraphy makes it possible to further consider the telegraph alphabet from the standpoint of the number of the elements and the combinations thereof for each letter. This phase of the problem is now being studied by the Code Section of the Signal Corps.

"In the Morse alphabet we find the principle of different time units for dots, dashes and spaces as the basic idea of the system. In Standard Morse a dash is three times the length of time of a dot, and the spaces between letters and words are timed correspondingly.

"These signals in International Morse are universally emitted into the ether from the transmitting antenna in the form of sudden interruption in the antenna current, or sudden variations in this current. This method produces about the worst possible source of disturbances in the ether space for the reason, among others, that the disturbance has no regularity of any kind, and the speed of operating the sending key has a marked influence on the whole phenomena. Present practice is drifting away from the complete interruption of the antenna current which is the worst from an interference standpoint, but the present methods of irregular variations of the current are still a long way from the possible scientific solution."

### Enclosed Switch

The Allen-Bradley Co., Milwaukee, Wis., has added a fourth item to their list of radio products, known as the Bradleyswitch.

This is a very compact, completely enclosed, single-pole switch for opening battery circuits. It is mounted by drilling a hole in the radio panel and securing the switch by means of a knurled nut. The switch is operated by pulling or pushing the switch button.

The Bradleyswitch is nickel plated and the button is polished black, thus conforming with the standard finish used for radio equipment. The switch will retail for 60 cents.

# Public Sales

We Have Purchased

## 122,000 Pair

U. S. ARMY MUNSON LAST SHOES

Sizes 5½ to 12, which was the entire surplus stock of one of the largest U. S. Government shoe contractors.

This shoe is guaranteed one hundred per cent solid leather, color dark tan, bellows tongue, dirt and waterproof. The actual value of this shoe is \$6.00. Owing to this tremendous buy we can offer same to the public at \$2.95.

Send correct size. Pay postman on delivery or send money order. If shoes are not as represented we will cheerfully refund your money promptly upon request.

### National Bay State Shoe Company

296 Broadway, New York, N. Y.



**ELECTRAD LEAD-IN**  
Fits right under closed window. Can be bent to fit ledges. Covered with fireproof insulating material, preventing grounding of circuits on wet window sills. Takes place of ungainly porcelain tubes and holes in the window sash. At your dealers', or order direct. **ELECTRAD, Inc.** 428 Broadway, New York Dept. S.

**40¢**

**\$3 DOWN** Brings you a Genuine **UNDERWOOD** TYPEWRITER

**10 DAYS FREE TRIAL** Your \$3.00 unconditionally returned if at end of 10 days you are not satisfied with this late model UNDERWOOD typewriter rebuilt by the famous Shipman Ward process.

**GREAT PRICE SAVING** Direct to you from the largest typewriter factory of its kind in the world by our money saving methods.

**EASY MONTHLY PAYMENTS** So small that you will not notice it while you enjoy the use of this wonderful machine.

**FREE BOOK OF FACTS** Explaining Shipman Ward's wonderful system of rebuilding typewriters and also valuable information about the typewriter industry both instructive and entertaining.

Act Today! Mail Coupon



**5 Year Guarantee**

Shipman Ward Mfg. Company  
3079 Shipman Building  
Montrose & Ravenswood Aves., Chicago

Please send me a copy of your free book of facts, explaining bargain offer.

Name.....  
St. and No.....  
City..... State.....

Radio's Best Bet  
—RADIO TOPICS

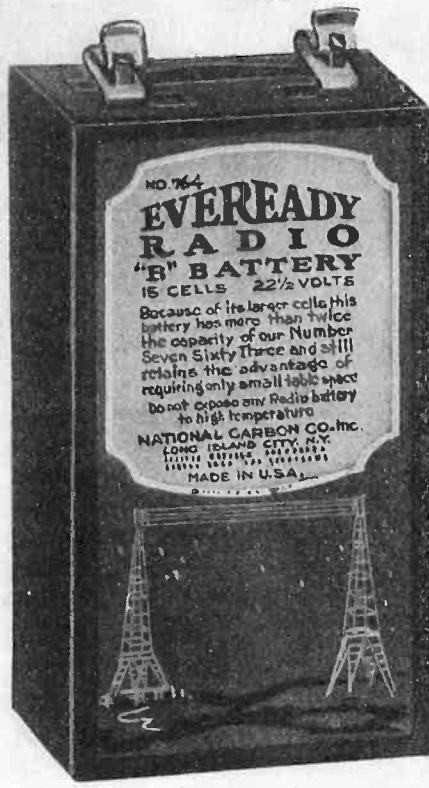

The Eveready "Skyscraper" battery

## Another New Battery

A NEW type of "B" battery constructed on the skyscraper principle, so that most of its bulk is raised vertically instead of occupying valuable horizontal space, is now available to radio fans whose table area is limited. The new battery is No. 764 of the National Carbon Company. It gives 22½ volts, and is only 3⅛ inches wide. Its height is 5⅝ inches.

It has been the practice of many radio users to install in their home sets the small "B" battery designed for portable sets, in situations where the saving of space or in first cost were considerations. Some set manufacturers, to provide cabinet space, have done the same thing. Although the small "B" battery is necessary for portable use, its small size gives so short a life that it is properly used only where small space and light weight are of first importance.

The new battery has twice the life of the portable battery, while standing on practically the same size base, and the cost is only about one-fourth more than the cost of the small one. It has developed after months of experimentation by engineers of the National Carbon Company, who knew that many radio users were increasing their battery operating cost in order to economize on space or to save in first cost.

Reliable **RADIO** Goods

### Distributors for:

Radio Corporation of America

- |                  |              |
|------------------|--------------|
| Grebe            | Western Coil |
| Atwater Kent     | Magnavox     |
| Brandes          | Burgess      |
| Murdock          | Gould        |
| Nath. Baldwin    | Eveready     |
| Western Electric | Frost        |
| Acme             | Carter       |
| All American     | Dubilier     |
| Signal           | Howard       |
| Chelsea          | Eby          |
| Cutler-Hammer    | Bradley      |
|                  | Jewell       |

and other standard manufacturers

We carry a comprehensive stock of the latest receiving sets, parts and supplies of the leading manufacturers and ship from stock promptly.

**Free Catalog** Illustrated, sent on request.

Dealers: Buy reliable equipment from a house of established reputation. Send for catalog of tested and approved apparatus and our discount sheet.

**Julius Andrae & Sons Co.**  
114 Michigan St. Milwaukee, Wis.

**ANDRAE** In Business Since 1860

# PATENTS

## To the Man with an Idea

I offer a comprehensive, experienced, efficient service for his prompt, legal protection and the development of his proposition. Send sketch of model and description, for advice as to cost, search through prior United States patents, etc. Preliminary advice gladly furnished without charge. My experience and familiarity with various arts frequently enable me to accurately advise clients as to probable patentability before they go to any expense.

Booklet of valuable information and form for properly disclosing your idea free on request. Write today.

**RICHARD B. OWEN, Patent Lawyer**  
81 Owen Bldg., Washington, D. C.  
2278-M Woolworth Bldg., N.Y. City



# Everybody's Building "Sun" Sets

The  
Marvelous  
New  
Non-  
Regenerative  
Circuit

(Patent  
Applied for)

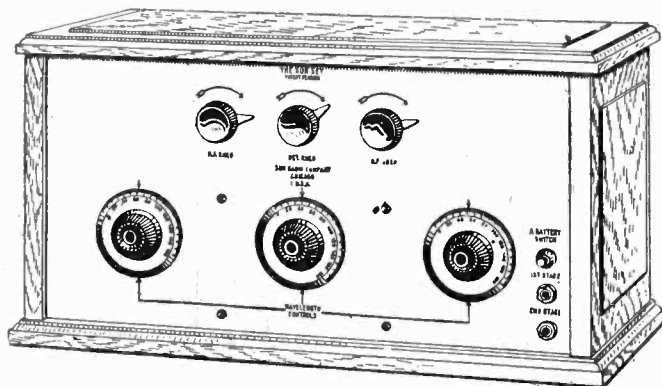

Phenomenally successful results through development of accurately balanced counter Electric Motive Force. Superior in range and selectivity to most 5 to 8 tube sets. Wonderful new principle brings in quality and volume of tone unequalled. Reproduces piano or the elusive notes of the soprano as faithfully as if the artist were in the room. Loud-speaker long-range and volume surpass local reception of other sets at any price. Entirely free from distortions, howls, squeals or hissing spill-overs common to other sets. There is no other set like the "Sun."

## Build It Yourself!

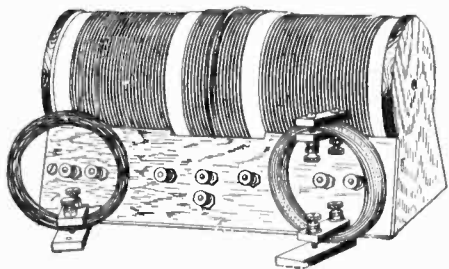

THIS IS THE  
SECRET

Special "Sun" Tuner Unit,  
Including Sun Loading Coil  
and Sun R. F. Transformer,

Only **\$24.00**

With This "Sun" Tuner Unit and Standard Parts  
It Is Easy to Assemble a Genuine "Sun" Set

We furnish complete list of parts and instructions for assembly so comprehensive that any one can understand and follow them. If you prefer to order a "Sun" Receiving Set, as illustrated, the price is \$175. Established dealers everywhere are prepared to furnish the "Sun" Tuner Unit at \$24, or completely assembled "Sun" Receiver Sets at \$175. If your dealer cannot supply you, we will ship direct on receipt of check or money order.



**SUN**  
RADIO  
COMPANY

4884-90 N. Clark St. Chicago, U. S. A.

Phone Ravenswood  
5916

## Deaf Are Grateful for Radio

**I**N the hurry and excitement of equipping millions of homes with radio sets, or the parts from which sets are made, few have paused to consider what this great new force means to those unfortunates who are hard of hearing.

Theodore Roosevelt said that it was not until he was eight years of age that he was provided with eye

glasses, and his own words are, "a new world was opened to me." What glasses did for Roosevelt, radio does for the deafened.

Annetta W. Peck, secretary of the New York League for the Hard of Hearing says, "Make this distinction between deaf and deafened. The former are born without the sense of hearing. Radio cannot help here. But for the latter, radio is one of the greatest alleviations." She herself is an enthusiastic radio listener, with acquired deafness.

The following letters will be of interest to every radio enthusiast, and will perhaps inspire taking the message to some of the afflicted:

Mr. Warren Pond, President,  
The New York League for the  
Hard of Hearing,  
126 East 59th Street, New York.

My Dear Sir: Your organization has been called to my attention in connection with the following:

I met a man afflicted with defective hearing. He said that he had not heard a public musical performance since the age of ten years, nor had he heard a public lecture, nor a theatrical performance in his life. Contact with fellow beings was limited and laborious.

Then along came radio. He purchased a good receiving set and now hears without difficulty the things which he has craved to hear for so many years.

This opened a new line of thought to me, and I wondered whether your organization is aware of what radio does for the hard of hearing.

My only interest is, if possible, to bring this wonderful thing called radio into the lives of those who may be struggling under the burden of loss of contact with fellow beings through the sense of hearing.

Yours very truly,  
The National Association of Broadcasters,  
Paul B. Klugh, Executive Chairman.

\* \* \*

Paul B. Klugh Executive Chairman,  
The National Association of Broadcasters,  
New York City.

My dear Sir: Your letter of October 18 in which you refer to the case of a man whose defective hearing had developed in him a degree of self-isolation and discouragement was exceedingly interesting to me. The man whose acquaintance you made is a typical instance of what happens to the individual who experiences gradual deafness, and the isolation which comes from it.

When I was 15, typhoid fever left me with impaired hearing. The trouble has grown worse since. I paid little attention to radio at first, having learned by hard experience not to put myself in the way of disappointment. Upon the insistence of friends I listened one night, and heard enough to decide me. The machine I bought had to be a powerful one—six tubes—but I'm not ashamed to confess that the first night, as I sat there in my own home and heard music clearly and without strain for the first time in forty-six years, tears came to my eyes.

This League has installed a set and, working with deafened people of all ages, both children and adults, of every degree of impaired hearing, we are able to give endless delight to groups of twenty-four simultaneous listeners using individual head sets, which work better for us than a loud speaker.

Our radio gives more real pleasure than any other means of entertainment for the deafened that we have ever tried.

Warren Pond, President.

# The COURT JESTER of TODAY

*"No wit to flatter left of all his store,  
No fool to laugh at, which he valued  
more."*  
—Pope.

SINCE the earliest days, laughter and gaiety have been the most sought after things in life. In ancient times stately rulers unbent, courtly knights forgot seriousness; beautiful ladies became more alluring as the clever quips and merry pranks of the court jester brought a sparkle to their eyes and drove dull care away. But they were limited to the clownish antics and slap stick comedy of the jester.

Moderns have unlimited sources of amusement. Every broadcasting station has its Jester; its humorous stories; amusing songs and clever comedies. Each night the air is filled with merriment.

With a Crosley Model X-J radio receiver, amusement may be brought clearly and distinctly to your fireside. Sitting comfortably in an easy chair you forget dull care. The magic wand of the radio sends worry scurrying.

The very moderate prices of all Crosley instruments bring radio within the reach of all. No matter which Crosley Model you may select you can be assured of the maximum results at the lowest cost. Let a Crosley Radio Receiver bring fun, laughter and good humor into your home.

**CROSLEY**  
Better - Cost Less  
Radio Products

See the Crosley Line at Good Dealers Everywhere

Write for Free Catalog. This fully describes the Crosley line of Radio receivers which range in price from the Model VI, a 2 tube set at \$30, to the graceful Console Model X-L at \$140. It also shows the complete line of Crosley parts.

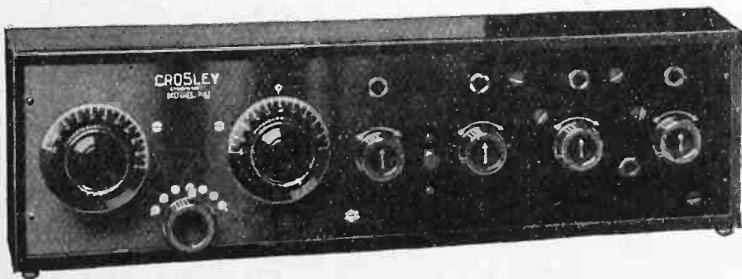

Crosley Model X-J—Price \$65

For tuning out local interference and bringing in distant stations this receiver is unexcelled. It is a 4 tube set combining one stage of tuned radio frequency amplification, detector and two stages of audio frequency amplification.

For bringing in distant stations no set can excel it.  
Cost of necessary accessories \$40.00 and up.

**CROSLEY MANUFACTURING COMPANY**  
Powel Crosley, Jr., President  
123 Alfred Street Cincinnati, Ohio  
*The Largest Manufacturers of Radio Receivers  
in the World.*

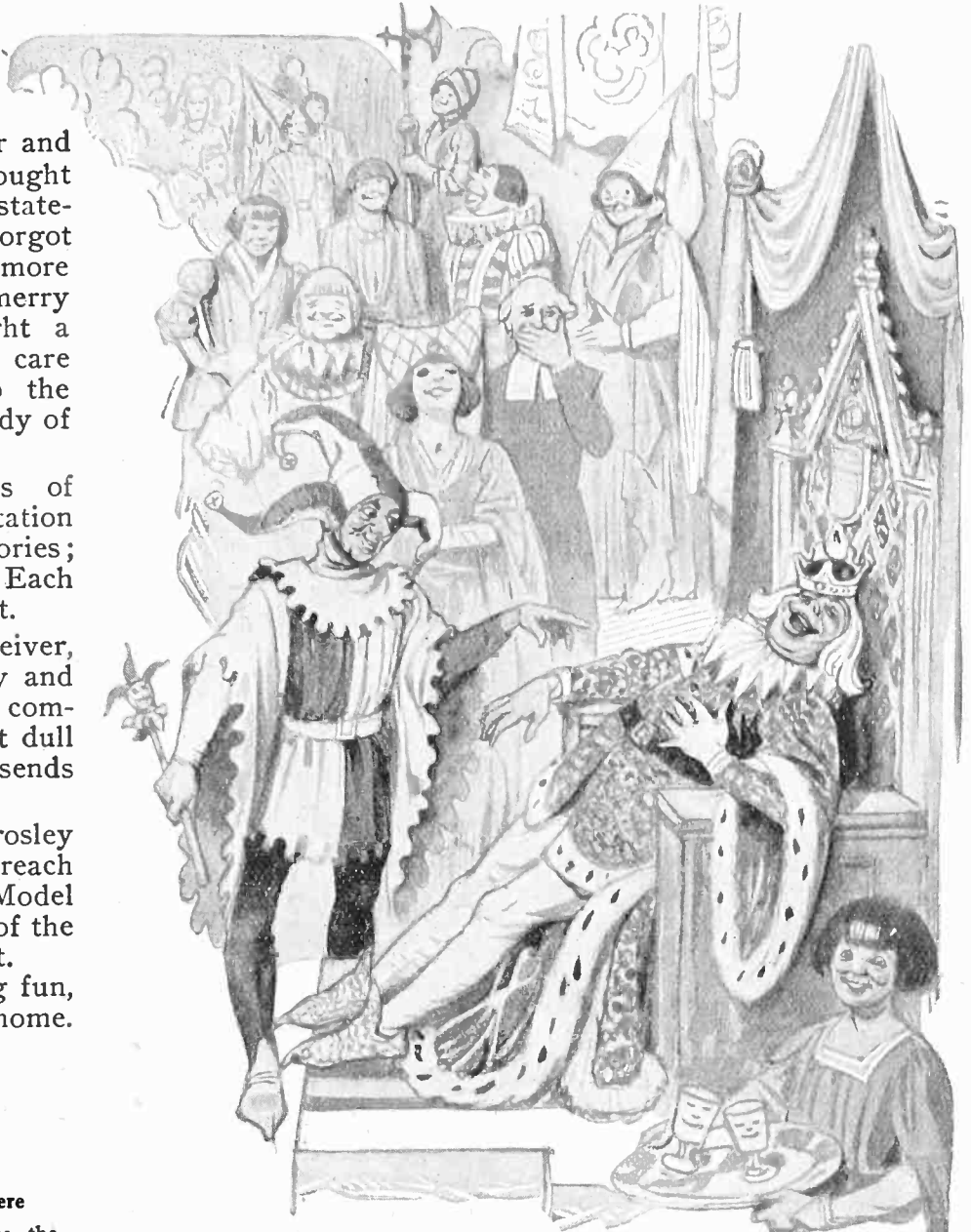

**CROSLEY** \$  
*Model X-J* **65**

CROSLEY MANUFACTURING COMPANY owns and operates Broadcasting Station WLW

**MAIL THIS COUPON TODAY**

Crosley Manufacturing Co.,  
123 Alfred St., Cincinnati, O.

Gentlemen: Please mail me free of charge your complete catalog of Crosley instruments and parts.

Name \_\_\_\_\_

Address \_\_\_\_\_

**Complete  
Your  
Radio Outfit**



**Bring Out the Best in Your  
Receiving Set with a Bristol**

TRADE MARK  
**AUDIOPHONE**  
REG. U. S. PAT. OFFICE  
**LOUDSPEAKER**

**I**T took six years to develop and perfect the Audiophone. That is more time than the average person cares to spend on a Loud Speaker for his receiving set.

But here it is, all ready for you to use by simply connecting to the set.

No auxiliary batteries are necessary.

The tone is big, full, and rich, and without that scratchy, tinny noise so often heard in receiving. It can easily be heard all through the house, so that your own family and friends can enjoy it with you.

The finish is a beautiful dull gold bronze.

Made in three sizes.

Senior Audiophone ..... Price **\$32.50**

Junior Audiophone ..... Price **22.50**

Baby Audiophone ..... Price **12.50**

When signals are not sufficiently loud to give good results with the loud speaker, Bristol One-Stage Power Amplifier is recommended to build up the power so that it can be heard even in a large hall. Price **\$25.00**

Ask for Bulletins Nos. 3006 and 3011-P.

**THE BRISTOL COMPANY**  
WATERBURY, CONN.

**The Ideal Radio  
Announcer**

**M**Y ideal radio announcer would be not only invisible, but inaudible as well. He would simply fade out of the air after the manner of the announcer on the phonograph records. I have mentioned this to many radio fans and they are unanimous in declaring that I am crazy. They say that the majority of radio listeners hesitate on one wavelength just long enough to get the call letters, and then they're on the wing again.

Very well. It is always a human characteristic to shout the impossibility of dispensing with an existing system of affairs when nothing tangible appears to take its place. But I am of the opinion that radio programs have a big evolution ahead of them, and that they will not remain in their present fragmentary sandwiching for a great length of time. The very fact that operas and plays are successfully broadcast shows conclusively that it is not a positive requisite for the well being of the program that the announcer waltz up to the microphone every four minutes with a mouthful of stereotyped phrases.

Now what's the solution? In the first place, a lot of work. So much work, in fact, that no one mixed up with the present whirlwind of radio broadcasting has time for it. A radio program should be worked out a long time in advance. It should be rehearsed. It should be a perfect production. It should be so radio programmishly arranged that the call letters of the station, or some signal significance, would fall in at proper intervals without destroying the continuity of the performance. The entire printed program should be in the hands of the radio listener a week before it is actually given. Anyone with experience would know his station by the position of his dials, and he would pick out the program he wanted most to hear.

The name of any station that relies upon curiosity of distance to attract unto itself a large audience is Dennis. The radio audience of today is much more discriminating than it was a year ago. The ratio of its critical attitude of demanding good entertainment to long distance reception is pretty apt to constantly increase. And of all forms of public entertainment that ever existed, radio is most at

**Los Angeles to Chicago  
on a CRYSTAL Detector**

**Crystals are the Best Yet! KEEP YOURS**

At Los Angeles I receive WJAZ, Chicago, WOC Davenport, and many other distant stations on mine—you can do the same on yours. Folks come from all over Los Angeles to hear the one I made.

I show you how to make your crystal set into the best receiver you could hope to own. Send \$1.00 for detailed instructions and 2-color wiring chart or send stamped envelope for further information.

I have no parts or sets to sell. **LOREN E. TAYLOR**, 2497-B Beachwood Drive, Los Angeles, Calif.



Keep your Radio Topics on  
file as a ready reference



the mercy of public opinion. The stations that venture upon a path which the public does not approve will be called back into line. Those who lag behind will be invited to get out of the way. Eventually, in all probability, the announcer will be invited to get out of the way. And the ideal announcer will be he that slips gracefully out of the way.

**New Addition to Crosley Line**

**P**OWEL Crosley, Jr., president of the Crosley Manufacturing Company, Cincinnati, has just announced a new model—the Crosley Model XJ. This is very similar to the Crosley Model X, but it is equipped with new parts, including the new Crosley Condensers, with moulded plates; moulded composition sockets, which are smaller and neater than the porcelain sockets, and new Multistats in moulded cups. These Multistats are universal filament control rheostats for all makes of tubes.

The Model XJ also is equipped with a phone jack to plug in on one stage of audio frequency amplification. Removal of the plug automatically switches the signals to four tubes on the loud speaker, providing the operator has attached the loud speaker to the binding posts marked "output." Thus it is possible to tune in without maximum volume and to use three tubes for the phones whenever desired. The set is also equipped with a filament switch to disconnect all filaments without changing the tuning. A new radio frequency tuned amplifier coil permits elimination of interference. All binding posts are located on a sub-panel and all wires come in from the rear or bottom for use in connection with a battery cabinet. This set consists of one stage of tuned radio frequency amplification, detector and two stages of audio frequency amplification. Owners will be able to hear every large station in the United States this winter.

Don't Overlook—  
Radio's Best Bet  
—RADIO TOPICS

# T-100 Battery Charger

## The Best and Lowest Priced on the Market

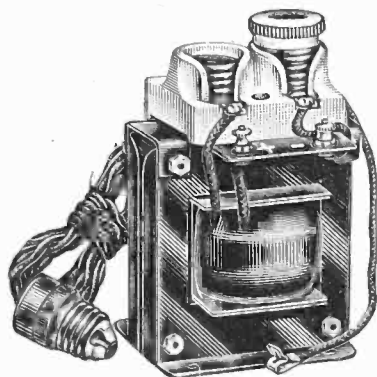

This battery charger operates on 110 volt, 60 cycle, A. C. circuit, charging a 6 volt battery at a 2 ampere rate. Standard 2 ampere charging tube is used. The T-100 is the lowest priced first-class charger on the market. Large numbers now in use have proved entirely satisfactory. No vibrating parts to get out of order. Absolutely noiseless in operation. Furnished with plug and cord for lamp socket. Battery leads marked. Fuse protects charger from accidental short circuit of 110 volt leads. Fully guaranteed.

Price complete, with 2 ampere tube, \$12.00.

### Our New Radio Guide Book Sent at Your Request

Our new 64-page Catalog No. TCR contains twenty of the most popular radio circuits printed in blue. These include the Hazeltine Neutrodyne, Grimes Inverted, Colpitts, Flewelling, Reinart, Diode Electrad, Heterodyne, Super-Regenerative and many others. Each article used in circuit is attractively pictured instead of appearing in straight schematic form. Besides containing blue prints, the best in radio is also illustrated and described. Cata-

log sent postpaid for ten cents. Each circuit worth double. Send for your copy today

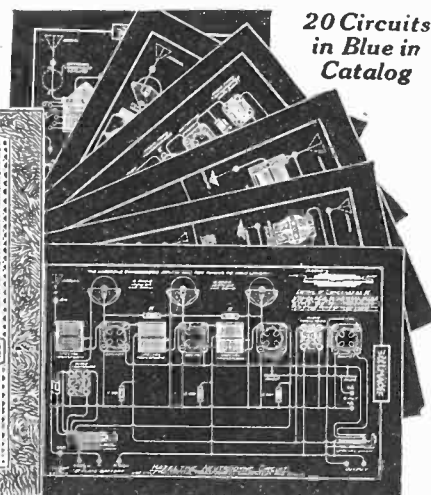

**JOBBERS** We have an attractive proposition for a few more bona-fide Jobbers

**DEALERS** If your Jobber cannot supply you order direct

**TELMACO**  
Quality Radio Exclusively

Radio Division  
**TELEPHONE MAINTENANCE CO.**  
20 So. Wells St., Dept. C, Chicago, Ill.



**NEW ELECTRAD DIODE**  
Replaces crystal in all circuits. Overcomes difficulties with reflex work. Gives greater volume, greater selectivity and steadies the circuit. No adjustments for change of wave lengths. Real results. Absolutely guaranteed. At your dealers, or order direct. Socket 50c.  
**ELECTRAD, Inc.**  
428 Broadway, New York  
Dept. S.



**INSIDE AERIAL**  
Substitute for Outside Antenna  
130 Feet Stranded Copper Wire  
**NOT A LOOP BUT A FULL SIZE ANTENNA.**  
Often doubles tone getting far stations in series with outside antenna  
Unaffected by Wind-Rain-Sleet-Lightning  
Suspend near ceiling

\$7 COMPLETE POSTPAID

**We Repair The Following Radio Tubes**

And Guarantee Them

WD-11 ... \$3.50	UV-199 ... \$3.50
WD-12 ... 3.50	C-299 ... 3.50
UV-200 ... 2.75	UV-201A ... 3.50
UV-201 ... 3.00	C-301A ... 3.50
C-300 ... 2.75	UV-202 ... 4.00
C-301 ... 3.00	C-302 ... 4.00
DV-6 ... 3.00	DV-6A ... 3.50

Mail Orders solicited and promptly attended to  
Dealers and Agents, write for Special Discount

**H. & H. RADIO CO.**  
P. O. BOX 22-R  
Clinton Hill Sta. Newark, N. J.

INTER-STATE SIGNALS (D), COLUMBUS, OHIO



# Save 1/3 on Guaranteed Radio Equipment

Write us a post card—  
Address Dept. 3-R

and we will send you free this 52 page catalogue of radio sets and parts. It also contains explanation of radio terms, map and list of broadcasting stations and much radio information, including an explanation of successful hook-ups and circuits.

You will be amazed at the low prices Ward's quote. A complete tube set having a range of 500 miles and more, including tube, head set, batteries, and antenna equipment, as low as \$23.50.

This catalogue contains everything for the expert and amateur. Complete sets and every improved part for building sets, all the most up-to-date devices—at the lowest possible prices.

### Headquarters for Radio

Montgomery Ward & Co. is headquarters for Radio, selling everything direct by mail without the usual "Radio-profits." Why pay higher prices? Ward quality is the best and the prices will often save you one-third. Everything sold under our Fifty Year Old Guarantee—Your Money Back if You Are Not Satisfied. Write today for your copy of this complete 52-page Radio Book.

Write to our house nearest you  
Address Dept. 3-R

Chicago Kansas City St. Paul  
Portland, Ore. Ft. Worth Oakland, Cal.

This Radio Catalogue  
**FREE**

# Montgomery Ward & Co.

The Oldest Mail Order House is Today the Most Progressive

## \$1 Loud Speaker \$1

**Radio Adapter**  
Hear all broadcasting through phonograph. Make your own horn. Attach B-R Phonadapter to YOUR phonograph. All can hear. Entire family, neighbors, guests can hear operas, lectures, latest news, with this adapter. Stretches over receiver of any standard type head-set and attaches to tone-arm of ANY phonograph. Made of soft, pure gum rubber. Quickly attached and removed. Thousands in use. Will not amplify or distort. For single receiver **.50**  
For pair of receivers (more than twice the volume) **\$1**

Go to your dealer. If he cannot supply you send money order, check or currency at our risk. Prompt delivery—postpaid. Also send us name of favorite radio dealer.

**The Beckley Ralston Company**  
1811 So. Michigan Ave., Chicago, Ill.

## Radio Tubes Repaired

We will repair your old tubes for you at following prices:

W-11, WD-12	_____	\$3.25
C-11, C-12	_____	3.25
UV-200, C-300	_____	2.75
UV-201, C-301	_____	3.00
UV-201-A, C-301-A	_____	3.25
UV-199, C-299	_____	3.25

Tubes guaranteed same as new.  
Tubes returned same day C. O. D.

### DEY'S RADIO SERVICE

Dept. F, 235 Pine Ave., Chicago, Ill.

## SEND NO MONEY



A limited quantity of Standard Make, high grade, fully guaranteed typewriters at lowest price ever offered.

### FREE TRIAL

for five days in your own home. Easy monthly payments. No "red tape". Send Today for Free Booklet of Valuable Typewriter Information, also Special Sale Bulletin.

**Smith Typewriter Sales Co.**  
—360 E. Grand Ave., Chicago, Ill.



### ELECTRAD VARIOHM

Each movement a definite new resistance. Positively does the work where others fail. Gradual resistance over entire range of 1/4 to 10 megohms. Eliminates circuit noises, moisture proof, non-microphonic. At your dealers', or order direct.

**ELECTRAD, Inc.**  
428 Broadway, New York

Dept. S.

## How to Test UV-199 Tubes

THE wide use and great popularity of the UV-199 Radiotron have led to numerous attempts on the part of unscrupulous manufacturers to counterfeit this tube. In external appearance some of the imitations bear such a close resemblance to the genuine tube that it is very difficult to detect the difference. Even the carton markings, the instruction sheets and the trade marks etched on the tube itself have been copied very closely.

However, in spite of the resemblance in appearance, the electrical characteristics of the counterfeit tubes are very different from those of the genuine UV-199. So far, none of the manufacturers of the illegal tube has been able to duplicate the 60 milli-ampere filament of the UV-199 and most of the counterfeits require as much as one-fourth of an ampere. Since the voltage of this filament can easily be made 3.0 volts or less, the user of such a tube is often misled by the apparently satisfactory operation when the tube is first lighted, but he soon finds that his dry battery is quickly exhausted and often the tube itself fails in a few hours.

Of course, the easiest way of determining the current required by the filament is to use a milli-ammeter and a voltmeter, but since such instruments are not in common use among radio experimenters, another simple method described below may be used which gives a rough approximation of the filament current.

Connect three new six-inch dry cells in series with the tube to be tested and an ordinary 50-watt, 110-120 volt Mazda vacuum lamp. Figure 1 shows the proper connections. If the filament of the tube being tested does not take more than 60 milli-amperes, it will light up almost to normal temperature. But, if the tube is not a genuine UV-199 and the filament requires appreciably more than 60-milli-amperes, the resistance of the Mazda lamp will rise due to the higher current flowing through it, and the voltage on the tube will be so low that its filament will not light. In making the test, be sure that the tube is left in the socket for about 30 seconds to allow the Mazda lamp filament to heat up to constant temperature.

# Railroad Fare



Student Winding a Stator

To the Great Shops of

# Coyne

We pay your railroad fare to Chicago—the Electrical Center of the World—from any place in the United States. Grasp the opportunity to see the country at our expense. Come to Coyne—learn electricity in 3½ months. Get a complete training so you can make big money as Power Plant Operator, Superintendent, Telephone man, Construction worker, auto, truck or tractor electrician, battery man, radio expert, or you can go into business for yourself as electrical contractor, dealer, auto ignition or battery expert and make from \$3,000 to \$20,000 a year. Hundreds of our graduates today are making big money and you can do the same if you grasp this opportunity—act now.

## Learn Electricity In 3½ Months

No books or useless theory. You are trained on \$100,000 worth of electrical equipment. Everything from door bells to power plants. You work on motors, generators, house-wiring, autos, batteries, radio, switch-boards, power plants—everything to make you an expert ready to step right into a position paying from \$45 to \$100 a week.

## Radio Course FREE

- We include the following free with the regular course;
- (1) A complete course in auto, truck and tractor electricity and storage batteries. Greatest outlay of auto, electrical and battery equipment in the country.
  - (2) Course in Radio—the marvel of the age. Constructing, installing and operating. You can build your own wireless telephone set.
  - (3) A life scholarship in the Coyne school. You can stay as long as you wish and return for further training at any time in the future.

### Earn While You Learn

We help students to secure jobs to earn a good part of their expense while studying.

## Send Coupon Now

Don't delay a minute—send that coupon in right now for our big free catalog and full particulars of Free Railroad Fare offer. Act now!

B. W. COOKE, President

Coyne Trade and Engineering School  
Dept. 5993 1300-1310 W. Harrison St., CHICAGO

B. W. Cooke, Pres. Coyne Trade and Engineering School,  
Dept. 5993 1300-1310 W. Harrison St., Chicago, Ill.

Dear Sir: Please send me free your big catalog and full particulars of your special offer of Free Railroad Fare and two extra courses.

Name .....

Address .....

.....

## ANNOUNCEMENT

# THE GREAT NORTHERN STEAMSHIP COMPANY

(Incorporated)

BOSTON, MASS.

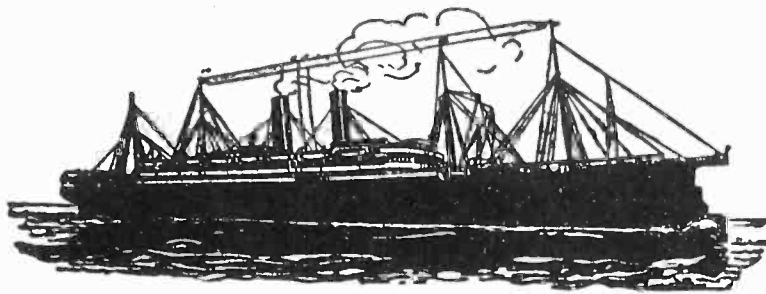

Announces that arrangements are now being made for monthly

## \$110 Round Trips to Europe

Boston—Southampton

**\$110**

ONE WAY \$65

Connecting for

London, Liverpool, LeHavre

Boston—Gothenburg

**\$138**

ONE WAY \$75

Connecting for

Christiana, Stockholm, Helsingfors, Danzig, Riga, Copenhagen

THE ABOVE PRICES INCLUDE RAILROAD FARES TO POINTS AS FAR NORTH AS STOCKHOLM

The Company plans to carry approximately two thousand passengers monthly. Make your plans now for a trip during the coming season.

Lives of passengers will be protected by

**EVER-WARM SAFETY-SUITS**

which prevent drowning and protect from exposure

A round trip, with all expenses on ship-board included, at no more expense than a vacation right here at home! To meet the ever increasing demand in this country for an inexpensive and at the same time thoroughly comfortable and enjoyable trans-Atlantic voyage, is the prime object of the Great Northern Steamship Company. Organized by progressive business men who realize the exceptional opportunity offered now for inexpensive travel in Europe, the Company will cater to the thousands of

intelligent persons who wish to visit the battlefields of France, the Shakespeare country, Scandinavia, the Land of the Midnight Sun, etc. A chance of a lifetime! So it would seem; but it is more than that. The Company is building for permanent business, setting a new standard of high-class ocean travel on a one-class basis. That this can be done at a fair margin of profit has already been proved and is further outlined in our prospectus. You'll find it extremely interesting.

WE WILL ALSO SHOW YOU HOW YOU MAY BECOME A PART OWNER IN THE MOST TALKED-OF ENTERPRISE IN YEARS

✂ Cut out and mail us with your name and address ✂

A. Wikstrom  
Information Dep't  
Edmunds Bldg., Suite 54  
Boston, Mass.

I am interested in securing full information regarding a trip to:

(Mark with a cross)	One way	Round trip
England	_____	_____
France	_____	_____
Germany	_____	_____
Sweden	_____	_____
Norway	_____	_____
Denmark	_____	_____
Baltic Provinces	_____	_____
Finland	_____	_____
Russia	_____	_____

A. Wikstrom  
Information Dep't  
Edmunds Bldg., Suite 54  
Boston, Mass.

I am interested in becoming part owner in the Great Northern Steamship Company.

Please send me proposition and full particulars.

Name \_\_\_\_\_

Street or R.F.d. \_\_\_\_\_

City or Town \_\_\_\_\_

State \_\_\_\_\_

Name \_\_\_\_\_

Street or R.F.d. \_\_\_\_\_

City or Town \_\_\_\_\_

State \_\_\_\_\_



**Blairco**  
Radio

Buy at the Radio Store where they display this sign—the distinguishing mark of Blairco Proven Products.



### ATLAS HEAD PHONES

The only high-grade receiver set offered at a reasonable price. Sensitiveness and adaptability positively is unequalled. Price \$9.00.

### Atlas Loud Speaker

Height over all, 21 in. Horn, 11 in. in diameter, of seamless vegetable fibre, dense and non-vibrating. Sound reflecting base and unit casing of dark red polished Bakelite. Priced complete with horn attachment and cord,

\$25.00.

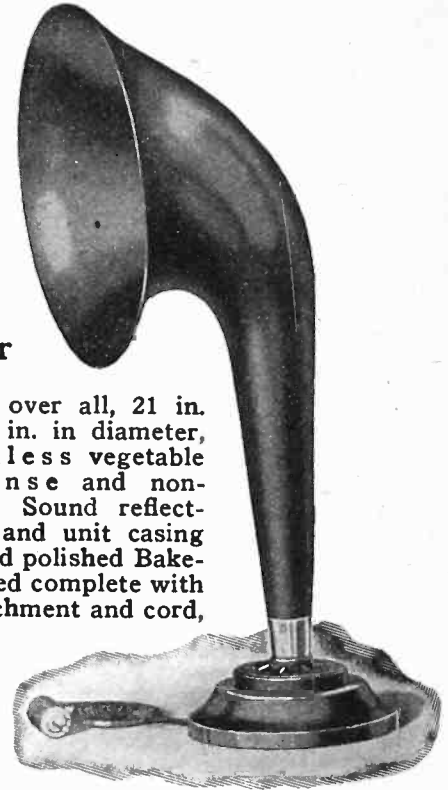

## The ATLAS Gives Tone Volume With Perfect Tone Control

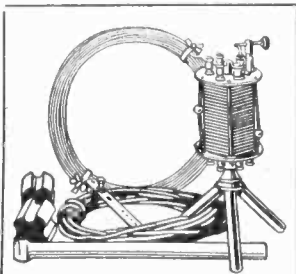

### Blairco "4" Crystal Set

Takes 4 head phones—Enables 4 to listen as well as 1. All nicked steel 9 in. high. Price only \$7.50.

Complete with copper clad aerial, water-proof lead-in and ground wire, strain and wall tube insulators, lightning arrester ground wire clamp and set of \$9.00 Blairco Headphones, \$17.50.

Dealers: An unbeatable profit opportunity is offered you in the Blairco Proven Products. Write quick for our proposition.

Multiplied enjoyment with your radio follows the use of a loud speaker which, set in any convenient spot, throws out the tones so that a roomful of family and friends can hear.

But in selecting the loud speaker, bear in mind that loudness without clearness is mere noise—and get an ATLAS.

With the Atlas you get the true tone of the original—clear, pure, exquisitely sweet—and perfectly controlled. Tone distortion, distracting mechanical sounds, confusing echoes and blasts—all are noticeably absent.

All is due to the patented double composition diaphragm—found only in the Atlas. And to the use of finer materials which, with scientific assembling, also insures permanence.

A typical example of the extra quality afforded at no extra cost by all radio equipment sold under the Blairco trademark.

No matter what you want in Radio, buy at the "Blairco" Radio store and get dependable value. Every article sold under the Blairco trade name, whether our own make or others, is of proved superiority. Exacting tests have proved it the best of its kind, bar none!

If you have no Blairco dealer, write us now for Folder and Prices

## Mitchell Blair Co.

"First With the Best"

1429 So. Michigan Ave., Chicago